



ABN:91 265 387 186

2026-2027 Rule Book

www.rhaa.com.au/rules

*Rules may be subject to change or amendment and are
to take effect as of 1st August 2026*

*This Rule Book is issued at the commencement of the show season. Updates including amendments,
additions, or corrections may be made throughout the year in accordance with RHAA procedures.
Amendments made from the previous rule book appear underlined.*

*Amendments made since 1 August 2026 are highlighted and reflected in the online version, which can
be downloaded at www.rhaa.com.au/rules*

MISSION STATEMENT

The Ranch Horse Association of Australia Inc (RHAA) is a not-for-profit, National Association dedicated to promoting "Ranch Horse" in Australia. Providing Ranch education, clinics, and events that support the growth of the free moving working horse and Ranch horse industry. Providing uniform guidance & rules across Australia, whilst supporting alignment with industry bodies, such as the AQHA, PHAA, AAA & the HSAA.

With representation from NSW, ACT, Victoria, Queensland, Tasmania, South Australia & Western Australia, the RHAA Inc formed a committee in October 2022, adopting a uniform set of rules to assist riders with all levels of experience and any breed of horse to enjoy all that Ranch has to offer.

TABLE OF CONTENTS.

SECTION		PAGE
1	MEMBERSHIP	6
2	ELIGIBILITY FOR COMPETITION	11
3	CLASSES	24
4	GEAR, ATTIRE & EQUIPMENT	61
5	GENERAL SHOW RULES	68
6	SHOW MANAGEMENT	79
7	JUDGING	92
8	POLICIES	99
9	PATTERNS	108

Index

SECTION 1 – MEMBERSHIP..... 6

- 1.1 MEMBERSHIP & FEES.....6
- 1.2 RIDER PERMITS:7
- 1.3 DIVISIONS:8
- 1.4 EOY HI POINTS8
- 1.5 EOY HP SCORING TABLE:.....9
- 1.6 EOY AWARDS:.....9
- 1.7 RIDER EOY HI POINT AWARDS10
- 1.8 HORSE EOY HI POINT AWARDS
10
- 1.9 EOY PROSPECT HI POINT
AWARDS.....10

SECTION 2 – ELIGIBILITY FOR COMPETITION..... 11

- 2.1 GENERAL:11
- 2.2 PROFESSIONAL RIDERS11
- 2.3 AMATEUR RIDERS11
- 2.4 LEVEL 1 – GREEN12
- 2.5 GREEN RIDER12
- 2.6 GREEN HORSE14
- 2.7 GREEN YOUTH.....15
- 2.8 LEVEL 2 – INTERMEDIATE16
- 2.9 INTERMEDIATE RIDER17
- 2.10 INTERMEDIATE HORSE18
- 2.11 INTERMEDIATE YOUTH18
- 2.12 LEVEL 3: HERITAGE SNAFFLE BIT
19
- 2.13 LEVEL 4 OPEN.....19
- 2.14 EQUESTRIAN WITH DISABILITIES
21

SECTION 3 – CLASSES.....24

- 3.1 MANDATORY FOR ALL LEVELS.
24
- 3.2 WESTERN GAITS 24
- 3.3 LEAD LINE 26
- 3.4 RANCH ON THE RAIL.....27
- 3.5 RANCH RIDING;..... 29
- 3.6 RANCH TRAIL: 31
- 3.7 RANCH REINING; 36
- 3.8 RANCH CONFORMATION..... 38
- 3.9 CATTLE CLASSES (GENERAL): . 39
- 3.10 RANCH CUTTING;..... 40
- 3.11 RANCH BOXING 42
- 3.12 RANCH ROPING 44
- 3.13 RANCH COW WORK..... 46
- 3.14 LIMITED RANCH COW WORK:50
- 3.15 RANCH PROSPECT LUNGELINE
53
- 3.16 RANCH PROSPECT TRAIL..... 57
- 3.17 RANCH PROSPECT
CONFORMATION 60

SECTION 4 – GEAR, ATTIRE, EQUIPMENT61

- 4.1 GEAR 61
- 4.2 ATTIRE 62
- 4.3 EQUIPMENT 62

SECTION 5 – GENERAL SHOW

RULES..... 68

- 5.1 SHOW RULES.....68
- 5.2 OTHER SHOW RULES & ETIQUETTE69
- 5.3 SUBSTANCES76

SECTION 6 – SHOW

MANAGEMENT 79

- 6.1 RHAA SHOW APPROVAL79
- 6.2 MISCELLANEOUS SHOW RULES 86
- 6.3 NATIONAL & STATE SHOWS ...86
- 6.4 SHOW TEAM;87
- 6.5 HIGH POINTS.....90

SECTION 7 – JUDGING 92

- 7.1 DIVISIONS.....92
- 7.2 DEFINITIONS93
- 7.3 AGES AND MEMBERSHIP93
- 7.4 JUDGES CONDUCT93
- 7.5 THE EVENT94
- 7.6 ATTIRE95
- 7.7 PLACINGS95
- 7.8 CONFLICT95
- 7.9 FEES.....97
- 7.10 AUTHORITY97

SECTION 8 – POLICIES..... 99

- 8.1 APPEALS99
- 8.2 COMPLAINTS MANAGEMENT POLICY 99
- 8.3 PRIVACY & PERSONAL INFORMATION MANAGEMENT POLICY 100

- 8.4 SOCIAL MEDIA & PUBLIC COMMUNICATION POLICY 101
- 8.5 ANIMAL WELFARE POLICY ... 101
- 8.6 PENALTIES AND RESTRICTIONS 102
- 8.7 CATTLE WELFARE POLICY..... 103
- 8.8 HEAT MANAGEMENT & EXTREME WEATHER POLICY 105

SECTION 9 – SHOW PATTERNS

..... 108

SECTION 1 – MEMBERSHIP

Members must:

1. Treat all Association representatives with courtesy, cooperation, and respect; and
2. Comply with these rules and regulations.

1.1 MEMBERSHIP & FEES

All Members are accepted on the same basis with equal rights: one ruling applies to all. Membership falls due on the 1st of August. Membership & a rider permit is required at the time of competition to obtain RHAA EOY Hi Points & LTE. (Lifetime earnings)

Membership fees from 1st August 2026, prices are inclusive of GST.

Family	\$166.00
EWD	\$25.00
Adult/Single	\$88.00
Youth	\$25.00
Day membership (no RHAA points)	\$55.00
Constituent	\$88.00
Associate	\$45.00
Life	\$880.00
<u>Affiliate</u>	<u>\$1,100.00</u>

Single Membership Single competitor 18yo and over.

Youth Membership; Any parent/guardian, including Non-competing parents or guardians who are nominated on the youth application or renewal agree to abide by the RHAA member 'code of conduct' in all aspects (refer rule 5.2.5).

Riders 7yo to 18yo - An individual person, eighteen (18) years of age and under as of 1 August in the current show year, is entitled to apply for a Youth membership.. Youth Membership is offered to all Youth aged 18 years and under. If a Youth turns 19 during a year, he/she shall remain in Youth Classes for the duration of that year. Youth may not ride or handle stallions at any time. All Youth riders must have a responsible guardian on the grounds as per rules. Youth members do not hold voting rights. All Youth riders must wear an ASS approved safety helmet when mounted on a horse regardless of the division they are riding in.

Family Membership consists of 2 adults and their dependents 18 years of age and under, residing at the same address. Only (1) one nominated member will have voting rights.

EWD Membership: Applicants must meet the eligibility criteria outlined in the RHAA EWD Policy and submit a completed and signed RHAA EWD Waiver, along with medical verification, prior to approval of EWD status.

Constituent; Constituent Members are persons (other than natural persons) that have been admitted as such and have paid the relevant annual membership fee. Constituent Members must appoint a Nominee.

Associate Membership: No voting rights, not eligible to compete.

Life Membership (Valid for 20 years from date of payment)

1.2 RIDER PERMITS:

Green rider, Intermediate rider, *Amateur	\$30.00
*Includes; Select Amateur & Masters	
Green Youth, Intermediate Youth, Youth	\$15.00

Disciplinary Action

The RHAA committee will act in accordance with its Constitution to reprimand, fine, suspend or expel a member, the representative of any member (being a Life Member, a Constituent Member or an Affiliate Member) if it considers that Member to be guilty of fraud, dishonesty, conduct unbecoming a Member, in breach of the Constitution and/or the Rules and Regulations of the Association, is prejudicial to the interests of the Association and any non-member will be fined and/or denied Association privileges. Failure to report a known infringement of these rules may also result in disciplinary action by the RHAA committee.

Rules and Regulations apply to all RHAA-sanctioned events, RHAA-conducted events, events run by RHAA affiliates, and any organisation granted program approval.

Green and Intermediate levels are governed by RHAA rules. AQHA-approved classes are adapted from the American Quarter Horse Association 2026 Rule Book.

1.3 DIVISIONS:

- Green Horse
- Green Rider
- Green Youth
- EWD
- Intermediate Horse
- Intermediate Rider
- Intermediate Youth
- Heritage Snaffle Bit
- Junior Horse
- Senior Horse
- Amateur
- Select Amateur
- Masters Amateur
- Youth
- All Age
- Lead line (non-point scoring)

1.4 EOY HI POINTS

- a) EOY Hi Point year runs from 1st August to 31st July.
- b) Points will be awarded to horses/riders based on their performance at shows run by the RHAA, as well as RHAA approved shows.
- c) For **Horse** classes (Green Horse, Intermediate Horse, Heritage Snaffle Bit, Junior Horse, Senior Horse, and All Age Horse) points are **awarded to the horse**.
- d) For **rider classes** (Green Rider, Green Youth, Intermediate Rider, Intermediate Youth, EWD, Amateur, Select Amateur, Masters and Youth) points are **awarded to the rider**.
- e) A **rider** (Amateur, Select, Masters, Green Rider, Green Youth, Intermediate Youth & Youth) can nominate a maximum of two horses per division to obtain points. If more than one horse is entered in any rider division, only the highest placed horse will be allocated points towards EOY high point awards at any approved show, when an individual rider places twice in one class.
- f) Membership must be current **prior** to commencement of a show to be eligible for points at that show.

The number of points awarded will be dependent upon the placing and the number of horses/riders in the class, based on a sliding scale system per the below table:

1.5 EOY HP SCORING TABLE:

# of Horses in Class	1 st	2 nd	3 rd	4 th	5 th	6 th	7 th
1	.5						
2-5	1	.5					
6-10	2	1	.5				
11-15	3	2	1	.5			
16-20	4	3	2	1	.5		
21-30	5	4	3	2	1	.5	
31-40	6	2	4	3	2	1	.5

For the **2026-2027** show season, all shows will be considered equal in value with only single points being awarded. The exception being multi-Judged shows whereby multiple sets of placings will yield multiple sets of points, Judges must be RHAA approved for points to be awarded.

State Shows will be awarded double points; **National Show** will be awarded triple points.

For breed societies National Shows where show approval has been given, **single points** will be allocated. Breed Society **State shows** are not eligible for RHAA approval or EOY Points.

1.6 EOY AWARDS:

- a) To be eligible for End of Year National High Point Awards a rider must be a current financial member with the RHAA. The horse/rider must show at a minimum of two RHAA approved shows throughout the show season which runs from 1st August to 31st July each year.
- b) The horse/rider that has accumulated the most points throughout the season from all classes contended within a division will be awarded National High Point Champion, with the horse/rider with the second highest number of points awarded Reserve National High Point Champion.

1.7 RIDER EOY HI POINT AWARDS

- Green Rider
- Green Youth
- Intermediate Rider
- Intermediate Youth
- Equestrians With Disabilities
- Amateur
- Select Amateur
- Masters
- Youth

1.8 HORSE EOY HI POINT AWARDS

- Green Horse
- Intermediate Horse
- Junior Horse
- Senior Horse
- Heritage Snaffle Bit
- All Age

1.9 EOY PROSPECT HI POINT AWARDS

- Yearling
- 2-3 year old

SECTION 2 – ELIGIBILITY FOR COMPETITION

2.1 GENERAL:

- a) No horse shall be entered in more than three (3) divisions, including youth per show, or as to cause mental or physical distress.
- b) No horse is to be shown by more than 1 rider in any class.
- c) Unregistered horses must provide a proof of age certificate supplied by a veterinarian to enter Ranch Prospect, Amateur, Select Amateur, Masters, Junior Horse, Senior Horse, Youth or All Age events.
- d) Financial Membership is NOT required by the owner of a horse for it to be entered & receive RHAA EOY & lifetime points.
- e) RIDERS/HANDLERS **must be** financial for both the horse & rider to receive points.
- f) Points and experience in other breed associations and disciplines for similar events, must be considered when assessing eligibility for a division.
- g) Show committees and the RHAA have the right to refuse entry in a chosen division due to previous experience.
- h) Membership is not required to compete at an approved show; however, competitors must meet RHAA eligibility requirements to enter any class at an RHAA sanctioned event.

2.2 PROFESSIONAL RIDERS

A 'professional' rider, HAS, in the previous three (3) years from the date of competing, received remuneration or compensation for. Showing or training any horse, instructing any other person in riding or exhibiting.

2.3 AMATEUR RIDERS

- a) Person must be a financial member of the Association and hold either an individual Full, Life or Honorary Life membership in their own name
- b) The amateur must abide by the following:
 - i. Has not, in the previous three (3) years received remuneration or compensation for: Showing or training any horse or instructed any other person in riding or showing.

- ii. Payment by another person for stable and or yard fees, bedding or camping fees will not be considered remuneration if the Amateur reimburses the payee.
- iii. Prize money or judging fees will not be considered as remuneration.
- iv. Amateurs may accept Sponsorship in the form of goods only.
- v. Exception would be Amateurs fundraising for a sanctioned RHAA event.
- vi. An Amateur can only exhibit a horse owned by themselves or their immediate family in any class.
- vii. Separate legal entities, such as family corporations, trusts or partnerships, are also authorised owners of the Amateur exhibitor's horse so long as all legal and equitable owners and beneficiaries of the legal entity are individuals specifically authorised by this rule;
- viii. Immediate family – Spouse, de facto partner, parents, child of the family, grandparents, brother(s), sister(s);
- ix. Horses owned in partnership or jointly with any person other than the persons immediate family, do not fulfil the ownership requirements for Amateur;
- x. Ownership of horses exhibited by the Amateur must be evidenced
- xi. Must hold an RHAA Amateur Permit to obtain RHAA EOY Hi Points & LTE.

2.4 LEVEL 1 – GREEN

2.4.1 GREEN DIVISION EQUIPMENT RULES

- a) Horses must be ridden two-handed in a snaffle bit with split reins, mecate rein or hackamore only.
- b) Any safe saddle may be used (English, Western, stock, fender).
- c) Horse ownership is not required (borrowed horses permitted).

2.5 GREEN RIDER

This division is for riders with little to no previous show experience. Points/earnings in any other equestrian disciplines count toward eligibility.

The Green Rider division exists to give genuinely inexperienced riders or those with physical or mental limitations that make cantering unsafe, providing a supportive and confidence-building place to show. This class is specifically designed for riders who are still developing basic control and confidence before progressing to canter-based divisions. It removes pressure, keeps expectations simple, and allows new riders to

gain experience safely.

Examples of eligibility for Green Rider:

- a) A rider who has never shown before.
- b) A rider who becomes anxious when asked to canter and needs more time to develop confidence.
- c) A rider recovering from injury or with a condition that makes loping difficult or unsafe.
- d) A mature-age rider returning to showing and not yet ready for faster gaits.

Class Requirements

- a) Walk and trot only — no loping/cantering permitted.
- b) Riders are not eligible to enter any other ridden division.
- c) Has not previously competed in any cattle or speed events or any discipline where loping/cantering is required.
- d) An exhibitor cannot show more than one (1) horse in the same class and a horse cannot be shown by more than one exhibitor in the same class.
- e) Once a rider competes in another division, they are no longer eligible to return to the Green Rider division, unless written approval is granted by the RHAA Appeals Committee.
- f) A Green Rider cannot have ever been paid or received in lieu goods to train, show, or assist in training horses in any capacity in any discipline.
- g) No Ranch Cattle or Ranch Reining events for Green Riders.

Eligibility Requirements

Must meet eligibility requirements &/or hold a current RHAA Green Rider Permit to receive RHAA EOY Points.

Special Consideration: Competitors that may be ineligible, however believe they have extenuating circumstances may apply in writing to the Appeals Committee via email; appeals@rhaa.com.au prior to entries.

Pointing-out Rules;

- a) EOY Hi Point Champion must move to Intermediate Rider the following season.
- b) 80 cumulative Green Rider LTE points = point out.
- c) Rider may finish the season after pointing out.

2.6 GREEN HORSE

The Green Horse division is designed for horses in the earliest stages of their show career. It provides a low-pressure, educational environment for horses who are still learning to settle at shows to offer exposure, perform basic patterns, and handle the general atmosphere of competition. The focus is on developing foundation, confidence, and gaining exposure, not advanced manoeuvres or cattle work.

This division is intended for genuinely inexperienced horses and is not a place for seasoned or professionally trained horses to compete in.

Examples of horses eligible as a Green Horse:

- a) A lightly started horse being introduced to its first few shows.
- b) A horse that needs confidence, miles before being asked to perform more complex manoeuvres.
- c) An inexperienced horse coming from a non-Western background (e.g., dressage, pony club) and transitioning to ranch events.
- d) A horse that has attended clinics but has not yet been shown.
- e) A horse that becomes anxious or distracted in a show environment and needs gradual exposure.

Green Horse Class Requirements

- a) Walk, trot, lope.
- b) No Ranch Cattle or Ranch Reining events for Green Horses.

Green Horse Eligibility Requirements

- a) Horses must have little to no prior show experience across any discipline.
- b) Points/experience in other disciplines (English or Western) count toward eligibility.
- c) Horses that have participated in professional aged-event programs (e.g., reining futurities, cow horse futurity/derby programs) are not eligible regardless of results.
- d) Horses that have been regularly shown or professionally trained for multiple seasons should progress to Intermediate Horse.

Restrictions for Green Horses

To ensure fairness and maintain the integrity of this development division: Green horses are NOT Eligible to enter any other division. Once horse enters another division they CANNOT return to Green Horse.

Pointing out rules:

- a) EOY Hi Point Champion must move to Intermediate Horse the following season.
- b) 85 cumulative Green Horse points = point out.
- c) Horse may finish the season after pointing out.

2.7 GREEN YOUTH

This division provides a safe, supportive introduction to showing for youth who are new to riding or competition. It removes pressure by limiting gaits to walk/trot and avoids cattle and reining events until the rider is more experienced.

Examples of Youth who fit this division:

- a) A child who has just begun independent riding.
- b) A young rider who needs supervision and walk/trot classes to build confidence.
- c) A youth rider who has no show experience.
- d) A nervous or easily overwhelmed rider who needs time before cantering or cattle work.

Class Requirements

- a) Walk and trot only — no loping/cantering.
- b) No Ranch Cattle or Ranch Reining events.
- c) Youth must be supervised by a responsible adult at all times.
- d) An exhibitor cannot show more than one (1) horse in the same class and a horse cannot be shown by more than one exhibitor in the same class.
- e) Green Youth are not eligible to enter any other ridden division
- f) Once rider enters any other division they are not eligible to return to Green Youth

Eligibility Requirements

- a) Written permission from parent/guardian required.
- b) Must meet eligibility requirements or hold a current RHAA Green Youth Permit to obtain RHAA EOY points.
- c) Points/earnings in other disciplines count toward eligibility.

Restrictions for Green Youth

To ensure fairness and maintain the integrity of this development division: Green Youth are NOT Eligible to enter Green Rider division.

Special Consideration: Competitors that may be ineligible, however believe they have extenuating circumstances may apply in writing to the Appeals Committee via email; appeals@rhaa.com.au prior to entries.

Pointing-out Rules;

- a) EOY Hi Point Champion must move to Intermediate Youth the following season.
- b) 60 cumulative LTE points = point out.
- c) May finish the season after pointing out.

2.8 LEVEL 2 – INTERMEDIATE

This division supports riders who are competent at all three gaits but are still developing the refinement, confidence, and show experience required for the higher Amateur levels.

Examples of who are eligible for Intermediate:

- a) A rider who is confident loping but not yet ready to show one-handed.
- b) A rider moving up from Green Rider who now feels comfortable at the lope.
- c) A rider who competes confidently in dry work but has minimal cattle experience (or vice versa).

General Intermediate Equipment Rules;

- a) 3yo+ horses must be shown one or two-handed in any legal Head-Gear, includes snaffle bit, hackamore, curb or romals.
- b) Riders may ride one or two-handed in a curb bit, but must not switch between one and two hands after commencing a class.
- c) Saddles: English, Western, stock, fender permitted (no bareback pads).
- d) Cattle events: Western/stock/fender only (no treeless).
- e) Borrowed horses permitted.
- f) Committees may refuse entry based on prior experience.

2.9 INTERMEDIATE RIDER

This division supports riders who are competent at all three gaits but are still developing the refinement, confidence, and experience required for the higher Amateur levels.

Examples of riders suited to Intermediate Rider:

- a) A rider who can lope confidently but cannot yet maintain correct one-handed bridle contact.
- b) A capable rider who is still developing timing and accuracy in reining-style manoeuvres.
- c) A rider wanting to try cattle classes for the first time.
- d) A rider returning to competition after a long break.

Class Requirements

- a) Walk, trot, lope.
- b) May ride one or two-handed in any legal head gear. (must not swap from one to two-handed in a curb bit)

Eligibility Requirements

- a) Must meet eligibility requirements or hold a current RHAA Intermediate Rider Permit to obtain RHAA EOY Points.
- b) Extensive cattle experience excludes riders from Intermediate cattle, but dry work remains permitted.
- c) Extensive dry/pattern experience excludes riders from Intermediate dry, but cattle remains permitted.
- d) Points/earnings across disciplines count toward eligibility.

Special Consideration: Competitors that may be ineligible, however believe they have extenuating circumstances may apply in writing to the Appeals Committee via email; appeals@rhaa.com.au prior to entries.

Pointing-out Rules;

- a) EOY Hi Point Champion moves to Amateur
- b) 200 LTE points (180 dry/20 cattle).
- c) May finish the season after pointing out.

2.10 INTERMEDIATE HORSE

This division is for horses that have developed beyond basic “Green Horse” exposure but still need more consistency before upper-level showing.

Examples of horses suited to Intermediate Horse:

- a) A horse that can perform patterns but still needs more consistency.
- b) A horse that is confident loping but learning more advanced manoeuvres.
- c) A horse transitioning from another non-Western discipline.
- d) A horse lightly shown but not extensively.
- e) A horse that is being trained into the bridle (curb or shank bit) but not ready to be ridden one-handed.

Class Requirements - Walk, trot, lope.

Eligibility Requirements

Points and experience in any discipline count toward eligibility.

Special Consideration: Horses that may be ineligible, however believe they have extenuating circumstances may apply in writing to the Appeals Committee via email; appeals@rhaa.com.au prior to entries.

Pointing-out Rules:

- a) EOY Hi Point Champion moves to All Age Horse.
- b) 190 LTE points (170 dry / 20 cattle).
- c) May finish the season once pointed out.

2.11 INTERMEDIATE YOUTH

For young riders who have progressed beyond walk/trot and are confidently loping but still need development before entering the full Youth division.

Examples of riders suited to Intermediate Youth:

- a) A Youth who can lope confidently but cannot yet maintain correct one-handed bridle contact.
- b) A Youth who has shown in non-Western disciplines but is new to ranch.
- c) A capable Youth who is still developing timing and accuracy in reining-style manoeuvres.
- d) A Youth wanting to try cattle classes for the first time.

Eligibility Requirements

- a) Must meet eligibility requirements or hold an Intermediate Youth Permit to obtain RHAA EOY Points.
- b) Same cattle/dry restrictions as Intermediate Rider.
- c) Points/experience in other disciplines count towards eligibility.

Restrictions for Intermediate Youth

To ensure fairness and maintain the integrity of this development division Intermediate Youth are NOT Eligible to enter Intermediate Rider division.

Special Consideration: Riders that may be ineligible, however believe they have extenuating circumstances may apply in writing to the Appeals Committee via email; appeals@rhaa.com.au prior to entries.

Pointing-out Rules:

- a) EOY Hi Point Champion moves to Youth.
- b) 150 LTE points (135 dry / 15 cattle).
- c) May finish the season once pointed out.

2.12 LEVEL 3: HERITAGE SNAFFLE BIT

Open to horses 3 years and over. Ridden two-handed in a snaffle bit with split reins regardless of horse's age. **Equipment:** Fender or stock saddle. (NO Western saddles permitted). The purpose of this class is to encourage experienced riders from other disciplines, without necessitating the need to purchase a Western saddle.

- a) Those entered in this division, if eligible, can cross enter, Amateur, Select Amateur, Masters, Intermediate Rider, Intermediate Youth and Youth & Intermediate Horse.
- b) **Ineligible** to cross enter Green Rider, Junior Horse, Senior Horse & All Age divisions.

2.13 LEVEL 4 OPEN

2.13.1 JUNIOR HORSE

- a) Open to all horses 3–5yo, and all level of rider with the exception of Green Rider.
- b) Can be ridden in a snaffle bit, hackamore, or one-handed in a curb bit. Western saddles only.

2.13.2 SENIOR HORSE

- a) Open to all horses 6yo and over, and all level of riders, with the exception of Green Horse or Rider.
- b) Horses MUST be ridden one-handed in a bridle, split reins, romal or two rein.
- c) Western saddles only.
- d) All Age may be offered in place of or additional to Junior and Senior horse.

2.13.3 AMATEUR

For those members of the Association, who are not professionals in the horse industry and who ride their horses for the pleasure of competing against other members who are also not professional. Competitors must meet all Amateur membership requirements to compete in this division.

2.13.4 SELECT AMATEUR

An amateur who has attained the age of 50 years and provides proof of age, which must be in the form of a copy of a driver's license or birth certificate.

2.13.5 MASTERS AMATEUR

An amateur who has attained the age of 65 years and provides proof of age, which must be in the form of a copy of a driver's license or birth certificate.

2.13.6 YOUTH

- a) Open to all Youth 7 to 18 years of age. If one (1) class is held to be: 7 to 18 years old if two (2) classes held: 7 to 13 years and 14 to 18 years.
- b) Must have written permission from their parent/guardian to be at that event.
- c) In the case of a Show the parent/guardian must also sign the entry form.
- d) All Youth competing or taking part in an RHAA sanctioned event must be in the care of a responsible adult who is in attendance for the duration of that event, whilst the Youth attends that event.
- e) Youth MUST ride in correct Head-Gear for horses age and attire as per RHAA Rules.
- f) A Youth can show non-owned horses in Youth classes and Open classes.

2.14 EQUESTRIAN WITH DISABILITIES

- a) If an affiliate chooses to include EWD classes, the RHAA does not assume responsibility for safety of participants.
- b) At any time in this section of the Rule Book where a handler is mentioned that handler is optional and if a handler is used then they must be dressed appropriately being Western style pants/jeans, enclosed safe shoes, shirt with sleeves and a Western hat.
- c) The Judge can set their own patterns for these classes but must keep in mind the limitations of the exhibitors. Eg: No picking up objects, no dismounting.
- d) Unable to cross enter any other 'ridden' division. May enter Ranch Prospect/led classes if able to compete unassisted
- e) There is no rider permit for EWD, however EWD membership will not be granted until a signed waiver has been received by the RHAA, and approved has been provided in writing.

Each participant needs to provide to the RHAA a waiver prior to competing that states the following:

I, name of address assumes all risk of personal injury or property damage and releases and discharges RHAA, RHAA Affiliates and Show Management, their respective Officers, Directors, representatives, and employees, from any and all liability, whenever or however arising, as to personal injury or property. Damage occurring as a result of participation in these classes, except for the negligent act or omission, if any, of said indemnities. If the participant is a minor, the parent or guardian, by allowing participation, assumes all risk of personal injury or property damage occurring as a result of the participation and does hereby release and discharge RHAA and Show Management, their respective Officers, Directors, representatives, and employees from any and all liability, whenever or however arising, from such participation, except for the negligent act or omission, if any, of an indemnity. Further, as parent or legal guardian, they agree to indemnify and hold harmless RHAA and Show Management from such liability to the minor.

- a) Each participant, and if a minor, the consenting parent or guardian, authorises the use of any picture, still or video which may be taken in conjunction with the exhibitor's participation in these equestrians with disabilities classes for the RHAA's official uses.
- b) Only geldings or mares can be shown.
- c) To show at an RHAA approved show, exhibitors must either be a member of the club running the show, or a member of AQHA if club is an AQHA affiliate

for insurance purposes. Day membership is sufficient for this purpose. Please note however that only current RHAA members will be eligible to receive points towards RHAA end of year high point and lifetime awards.

- d) An exhibitor cannot show more than one (1) horse in the same class, and a horse cannot be shown by more than one exhibitor in the same class.
- e) Exhibitors cannot compete in the Open/Amateur/Youth classes and Equestrian with Disabilities classes at the same show. The exhibitor must make a choice for that show.
- f) For participation in these classes, an exhibitor must produce a Doctors Certificate, upon joining the RHAA for the first time, which states the disability. Competitors from other recognised breed organisations must have Equestrian with Disabilities endorsement from their breed. That every five (5) years an exhibitor must re-apply for a permit.
- g) Youth participants must be seven (7) years of age or older for the ridden classes. Classes are walk or walk/trot only.
- h) Eligible Conditions Include: Amputation Arthrogyrosis
- i) Aspergers Syndrome Autism
- j) Batten's Disease
- k) Cerebrovascular Accident Cerebellar Ataxia Cerebral Palsy
- l) Coffin Lowry Syndrome Cystic Fibrosis
- m) Down Syndrome Dwarfism
- n) Fragile X Syndrome Friedreich's Ataxia Guillain-Barre Syndrome Hearing Impairment Hunter's Syndrome
- o) Juvenile Rheumatoid Arthritis Intellectual Disability Microcephaly
- p) Multiple Sclerosis Muscular Dystrophy Post-Polio Syndrome Prader-Willie Syndrome Rhatt Syndrome
- q) Spina Bifida Spinal Cord Injury
- r) Tourette Syndrome Traumatic Brain Injury Trisomy Disorders Vision Impairment
- s) Other diagnoses will be considered upon request.
- t) The exhibitor or their family does not have to own the horse.
- u) Handler – One (1) handler per entry in the arena to facilitate the safety of the rider. The handler must be eighteen (18) years of age or over. A halter must be on the horse, under the bridle, for use by the handler if needed. The handler must be appropriately attired and must have a suitable lead line in hand in case of need. Lead line cannot be fastened to the bit. Handlers will stand quietly as a group in a designated area of the arena unless their assistance is required and requested by the Judge or ring steward.

- v) A competitor with a hearing impairment can have an assistant who communicates via sign language or cue cards to the competitor so they can conform to the Judge's directives. This assistant will be outside the arena and their position known to the Judge and ring Steward.
- w) Ear buds are permitted when required.
- x) Refer to "GEAR" in regard to required Tack and equipment.

The following disorders are not eligible:

- a) ADHD
- b) Anxiety Disorders
- c) Chronic Fatigue Syndrome
- d) Depression
- e) Dyslexia
- f) Eating Disorders
- g) Fibromyalgia
- h) Learning Disabilities
- i) Psychological Diagnosis

No Ranch Cattle events or Ranch Reining for EWD.

SECTION 3 – CLASSES

3.1 MANDATORY FOR ALL LEVELS.

- a) No horse under 3 years of age may be exhibited under saddle.
- b) No hoof polish/black.
- c) No braided or banded manes/tails or tail extensions. except in any class where roping is involved, the horse's mane may be braided for a distance of 33 – 45cm in front of the saddle pad. No ribbons or other kinds of ornamentation will be allowed.
- d) Trimming inside ears is discouraged. Trimming bridle path is allowed, also trimming of fetlocks or excessive (long) facial hair.
- e) Equipment with silver should not count over a good working outfit. Silver on bridles and saddles is discouraged.
- f) Holding the saddle horn or front of saddle with either hand will not be penalised in any class.
- g) Posting or standing in stirrups at extended gaits is acceptable.
- h) When exhibiting in a snaffle bit or hackamore, an exhibitor may switch between two hands and one hand on the reins at any time.
- i) No drag permitted in EWD, Level 1 (Green) or Level 2 (Intermediate), Heritage Snaffle Bit, or Youth classes.
- j) Tie Breaker - specific manoeuvres and/or obstacles will be selected by Judge prior to start of the class and so noted on score sheets, these manoeuvres will be ranked as first tie breaker, second, third etc.
- k) Scoring: Each exhibitor is scored between 0-100 points and automatically begins the run with a score of 70 points. Exceptions; Conformation & Ranch On The Rail

3.2 WESTERN GAITS

The horse should be ridden at a speed which is a natural way of going. The head should be carried at an angle which is natural and suitable to the horses' conformation at all gaits.

3.2.1 WALK

Is a natural, flat-footed, four-beat gait. The horse must move straight and true at the walk. The walk must be alert, with a stride of reasonable length in keeping with the size of the horse.

- a) Poor - has an uneven pace and no cadence. Has no flow and may appear intimidated or appear to march.
- b) Average - has a four-beat gait and is relaxed.
- c) Good - has a flowing four-beat gait, is relaxed and is bright and attentive.

3.2.2 TROT

Is a smooth, ground-covering two-beat diagonal gait. The horse works from one pair of diagonals to the other pair. The trot should be square, balanced and with straight, forward movement of the feet. Horses walking with their back feet and trotting in the front are not considered performing the required gait.

- a) Unacceptable - cannot perform a two-beat gait and has no flow or balance in the motion.
- b) Poor - hesitates in motion. Does not keep an even and balanced motion and may appear to shuffle.
- c) Slightly below average - average motion but has negative characteristics such as: walking with hind legs, dragging the rear toes or taking an uneven length in stride with the front and rear legs.
- d) Correct or average - has a two-beat gait and a relaxed appearance.
- e) Good - has average motion with positive characteristics such as balance and self-carriage while taking the same length of strides with front and rear legs.
- f) Very good - comfortable to ride while having a consistent two-beat gait. The horse guides well and appears relaxed.
- g) Excellent - effortless and very efficient motion. Swings the legs yet touches the ground softly. Confident, yet soft with its motion while being balanced and under control. Moves flat with the knee and hock and have some cushion in the pastern. Has a bright and alert expression and exhibits more lift and self-carriage than the “very good trot”.

3.2.3 EXTENDED TROT

- a) When asked to extend the trot, the horse moves out with the same smooth way of going as in the trot (sit trot).
- b) Poor - never lengthens the stride and may appear rough to ride.
- c) Average - moves up in its pace and appears smooth to ride.
- d) Good - has an obvious lengthening of stride with a slight increase in pace while exerting less effort and appears smooth to ride.

3.2.4 LOPE

Is an easy, rhythmical, forward moving three-beat gait. Horses moving to the left should lope on the left lead. Horses moving to the right should lope on the right lead. The horse should lope with a natural stride and appear relaxed and smooth.

- a) Unacceptable - does not have a three-beat gait. Has no flow, rhythm, or balance. Uncomfortable ride.
- b) Horses travelling at a four-beat gait are not considered to be performing at a proper lope.
- c) Poor - appears to have a three-beat lope but has no lift or self-carriage. The horse shuffles, has no flow and bobs their head, giving the appearance of exerting a great deal of effort to perform the gait. Also, could be uncomfortable to ride.
- d) Slightly below average - an average motion but exhibits negative characteristics like head bobbing, not completing the stride with the front leg and leaving the outside hock well behind the horse's buttocks.
- e) Average - a true three-beat gait with very little head and neck motion. They are relatively straight (not over-canted); guides well and has a relaxed appearance.
- f) Good – has an average motion but exhibits positive characteristics in their performance like self-carriage, a steady top-line, relaxed appearance and is responsive to the rider's aids.
- g) Very good - more lift and flow than the average horse. Has a strong but smooth drive from behind. They may bend their knee slightly yet still exhibits self-carriage with a relaxed appearance. Appears comfortable to ride.
- h) Excellent - a round back with an effortless strong, deep stride with the rear legs and a flat swing with the front legs, a relaxed yet alert and confident appearance and correct but soft in appearance. A special horse with a great lift and self-carriage

3.3 LEAD LINE

Lead line Class Guidelines (Non RHAA Point Scoring)

3.3.1 ELIGIBILITY:

- a) Riders must be 3–6 years old as of 1st August in the year of competition.
- b) Riders in this class cannot enter any other ridden class on the program.

3.3.2 HORSE REQUIREMENTS:

- a) Horses must be 4 years and over (no stallions).

3.3.3 SAFETY REQUIREMENTS:

- a) Riders must wear an approved safety helmet.
- b) A lead rope at least 1.8 m long must be attached to a halter under the bridle.
- c) The chain on the halter must run straight off the halter ring (not under the chin or over the nose).

3.3.4 HANDLER REQUIREMENTS:

- a) The handler must be a responsible adult aged 18 years or older.
- b) The handler must hold full membership of the host club for insurance purposes

3.4 RANCH ON THE RAIL

The Ranch on the Rail class measures the ability of the horse to be a pleasure to ride and should reflect the versatility, attitude, and movement of a working horse. The horse should be well-broke, relaxed, quiet, soft and cadenced at all gaits. The movement of the Ranch on the Rail horse should simulate a horse needing to cover long distances, softly and quietly. The overall manners and responsiveness of the horse and the horse's quality of movement are the primary considerations. Maximum credit should be given to the horse that has a natural flowing stride and consistent, ground covering gaits. Transitions should be performed when requested, with smoothness and responsiveness. The ideal Ranch on the Rail horse should have a natural head carriage at each gait. The horse should be ridden on a relatively loose rein with light contact and without requiring undue restraint while being responsive to the rider and making timely transitions in a smooth and correct manner. The horse should be soft in the bridle, yield to contact and shall not be shown on a full drape of rein. Riders are encouraged to use adequate space given the extension of gaits required. This class should show the horse's ability to work at a forward, working pace while under control by the rider. The horse shall be balanced and appear willing and a pleasure to ride in a group situation. This class is open to horses three years of age and older.

Class Requirements:

- a) All exhibitors will work as a group. Individuals working off the rail will not be penalised, and passing is permissible.
- b) Horses must work both ways of the ring at the walk, trot and lope.

- c) Horses must work at least one way of the ring at the extended trot and extended lope. At the option of the Judge, horses may be asked to extend their stride at the walk.
- d) The overall cadence and performance of the gaits should be with an emphasis on forward, free-flowing, and ground-covering movement.
- e) At the extended trot and lope, the exhibitor may post or stand in the stirrups.
- f) Touching or holding the saddle horn or front of the saddle at extended gaits is acceptable.
- g) Horses are to be reversed to the inside (away from the rail). They may be required to reverse at the walk or trot at the discretion of the Judge but shall not be asked to reverse at the lope.
- h) Horses are required to back easily and stand quietly. Horses may be brought to the centre or backed on the rail.
- i) The rider shall not be required to dismount except in the event the Judge wishes to check equipment.

Faults scored according to severity:

- Too slow (any gait)
- Excessive speed (any gait)
- Over-bridled (nose behind the vertical)
- Head carried too low such that the poll is below the withers.
- Out of frame
- Head carried too high.
- Break of gait
- Wrong lead or out of lead
- Failure to take the appropriate gait when called.
- Opening mouth excessively
- Draped reins
- Use of spurs forward of the cinch
- Canted at the lope
- Blatant disobedience (kick, bite, buck, rear, etc.)

Faults which will be cause for disqualification: **(DQ)**

- Head carried too low and/or clearly behind the vertical excessively and consistently while the horse is in motion or otherwise showing the appearance of intimidation.

3.5 RANCH RIDING;

The purpose of the ranch riding class is to measure the ability of the horse to be a pleasure to ride while being used as a means of conveyance from performing one ranch task to another. The horse should reflect the versatility, attitude and movement of a working ranch horse riding outside the confines of an arena. The horse should be well-trained, relaxed, quiet, soft and cadenced at all gaits. The ideal ranch horse will travel with forward movement and demonstrate an obvious lengthening of stride at extended gaits. The horse can be ridden with light contact or on a relatively loose rein without requiring undue restraint but not shown on a full drape of reins. The overall manners and responsiveness of the ranch riding horse to make timely transitions in a smooth and correct manner, as well as the quality of the movement are of primary considerations.

Each horse will work individually. Horses will be scored on the basis of 0 to 100, with 70 denoting an average performance. Each manoeuvre will receive a score that should be added or subtracted from 70 and is subject to a penalty that should be subtracted. Each manoeuvre will be scored on the following basis, ranging from plus 1 ½ to minus 1 ½.: -1 ½ extremely poor, -1 very poor, -½ poor, 0 correct, +½ good, + 1 very good, + 1 ½ excellent. Manoeuvre scores are to be determined and assessed independently of penalty points. Natural ranch horse appearance will also be evaluated ranging from plus 1 ½ to minus 1 ½. One of the 15 approved patterns must be used, except at the RHAA National Show where alternate patterns may be used. The overall cadence and performance of the gaits should be as those described in WESTERN GAITS, with an emphasis on forward movement, free-flowing, and ground covering for all gaits. Transitions should be performed where designated, with smoothness and responsiveness. There is no time limit.

Sitting the regular trot and lope is recommended; though standing in the stirrups at the extended trot and extended lope, or posting the extended trot is acceptable. Touching or holding the saddle horn is acceptable. Ranch Riding Penalties. Manoeuvre evaluations and penalty applications are to be determined independently.

Natural ranch horse appearance will be evaluated ranging from plus 1 ½ to minus 1 ½.

The following penalties will be applied to each occurrence and be deducted from the final score:

One (1) point

- Too slow (per gait)
- Over-bridled (per manoeuvre)
- Out of frame (per manoeuvre)
- Break of gait at walk or trot for 2 strides or less
- Wrong lead or out of lead for 2 strides or less

Three (3) point

- Break of gait at walk or trot for more than 2 strides
- Break of gait at lope, except when correcting an incorrect lead
- Wrong lead or out of lead for more than two strides
- Draped reins (per manoeuvre)
- Out of lead or cross-cantering more than two strides when changing leads
- Trotting more than 3 strides when making a simple lead change
- Trotting for more than 3 strides in lope departures or exiting a rollback into a lope from a stop or walk
- Severe disturbance of any obstacle

Five (5) point

- Blatant disobedience (including, kicking, biting, bucking, rearing and striking) for each refusal

Off Pattern (OP) Placed below horses performing all manoeuvres

- Eliminates or adds manoeuvre
- Incomplete manoeuvre
- Repeated blatant disobedience
- Use of two hands (except horses shown in a snaffle bit/hackamore),
- More than one finger between split reins or any fingers between romal reins (except in the two rein)

Zero (0) score: (DQ)

- Abuse
- Illegal equipment including hoof black, braided or banded manes, or tail extensions
- Lameness
- Leaving working area before pattern is complete
- Disrespect or misconduct
- Improper Western attire
- Fall of horse/rider

No specific penalties will be incurred for nicks/hits on logs, but deduction may be made in manoeuvre score. No specific penalties will be incurred for over/under spins but deduction may be made in manoeuvre score.

3.6 RANCH TRAIL:

A Ranch Trail class should test the horse's ability to cope with situations encountered while being ridden through a pattern of obstacles generally found during everyday ranch work. The horse/rider team is Judged on correctness, efficiency, and pattern accuracy with which the obstacles are negotiated, and the attitude and mannerisms exhibited by the horse. Judging emphasis is on identifying the well-broke, responsive, and well-mannered horse which can correctly navigate and negotiate the course. The ideal ranch trail horse should have a natural ranch horse appearance from head to tail in each manoeuvre.

Class requirements.

The ranch trail course will include no less than six and no more than nine obstacles. It is mandatory that the horse be asked to walk, trot and lope during the course. Walk can be part of obstacle score or be scored with the approaching obstacle. Trot must be at least 10 metres and score with approaching obstacle. Lope must be lead-specific, at least 15 metres and score with approaching obstacle. Care must be exercised to avoid setting up any obstacles that may be hazardous to the horse or rider. Painted logs are prohibited.

When setting courses, management will be mindful that the idea is not to trap a horse/rider team or eliminate it by making an obstacle too difficult. All courses and obstacles are to be constructed with safety in mind so as to reduce the risk for accidents. Show committee shall have the option of setting up the trail course to best fit the arena conditions. An outdoor course is recommended if appropriate terrain is available. Each single-performance event can be time consuming, especially with large classes, so it is imperative that time restrictions are placed on this class. The show committee, either through a pilot run or estimation, shall select a course that has a continuous and positive flow.

Judges must walk the course and have the right and duty to alter the course if it is not in keeping with the intent of the class. Judges may remove or change any obstacles they deem unsafe, non-negotiable or unnecessarily difficult. Any time a trail obstacle becomes unsafe during a class, it shall be repaired or removed from the course.

If the course cannot be repaired and some horses have completed the course, the score for that obstacle shall be deducted from all previous draws in that class.

The course must be designed using the mandatory obstacles and manoeuvres plus optional obstacles. Combining two or more of the obstacles is acceptable.

PROHIBITED OBSTACLES: Tarps, water obstacles with slick bottoms, PVC pipe used as a jump or walk over, tires, rocking or moving bridges, painted logs or poles, logs elevated in a manner that permits such to roll in a dangerous manner, any type of pinwheel regardless of spacing or gait.

MANDATORY OBSTACLES AND MANOEUVRES

1. Ride over obstacles on the ground (natural logs are required). Walk, trot or lope may be used but only one gait is required.

Walk-overs: Walk over no more than four logs no more than 25cm high. The spacing between successive logs should be 65 – 75cm. The formation may be straight, curved, zigzagged or raised. Trot-overs: Trot over no more than four logs no more than 25cm high. The spacing between successive logs should be 91-100cm The formation can be straight, curved, zigzagged or raised. Lope-overs: Lope over no more than three logs no more than 25cm high. No more than two logs may be used in succession. The spacing between logs should be at least 1.8 metres. The formation can be straight, curved, zigzagged or raised.

2. Opening, passing through and closing a hinged swinging gate (not a rope gate): Use gate that will not endanger horse or rider and requires minimum side-passing.

3. Ride over wooden bridge: Bridge should be sturdy, safe and negotiated at a walk only. Heavy plywood lying flat on the ground is an acceptable simulation of a bridge. Suggested minimum width shall be 95cm wide and at least 1.8 metres long.

4. Backing obstacles: Backing obstacles are to be spaced at a minimum of 75cm. If elevated, 80cm spacing is required. Back through and around at least three markers. Back through L, V, U or straight or similarly shaped course which may be elevated no more than 60cm.

5. Side-pass obstacle: Any object which is safe and of any length may be used to demonstrate responsiveness of the horse to leg signals. Raised side pass obstacles should not exceed 30cm.

6. Drag an object: For amateur, select & master, junior, senior & all age horse **ONLY**. The drag is not to be used in any *youth, green, intermediate or heritage snaffle bit classes*. Drag may be a complete figure eight and may begin in either direction. The exhibitor must have the rope dallyed on the saddle horn (half or full dally)

OPTIONAL OBSTACLES. Optional obstacles may be used provided the obstacles can be found in everyday ranch work. Optional obstacles from which selections can be made include, but are not limited to:

- A jump obstacle whose centre height is not less than 35cm high or more than 60cm high and is at least 1.5m from side to side at the approach. Holding the saddle horn is permissible for this obstacle.
- Only live or stuffed animals which would normally be encountered in an outdoor setting may be used but not to be used in an attempt to spook a horse.
- Carry object from one part of the arena to another.
- Remove and replace materials from a mailbox.
- Trot through cones spaced a minimum of 1.8m apart.
- Cross natural ditches or ride up embankments.
- Swing rope or throw rope at a dummy steer head. **NB:** No roping in Heritage Snaffle Bit, Intermediate or Green levels
- Step in and out of obstacle.
- Put on slicker or coat.
- Stand to mount with mounting block.
- Walk through water obstacle.

- Open gate on foot.
- Pick up feet.
- Walk through brush
- Ground tie (hobbles are allowed).
- Lead at the trot.

CREDITS AND PENALTIES. All runs begin upon entering the area of competition and any infractions are subject to penalty at that time (such as two hands on the reins, using either hand to instil fear, etc.). The rider has the option of eliminating any obstacle; however, this will result in being **off pattern (OP)** and the horse/rider team may not place above others who have completed the pattern correctly. A Judge may ask a horse to pass on an obstacle after three refusals or at any time for safety concerns.

Credit is given to horse/rider teams who negotiate the obstacles correctly and efficiently. Horses should receive credit for showing attentiveness to obstacles and ability to negotiate through the course when the obstacles warrant it while willingly responding to rider's cues on more difficult obstacles. Quality of movement and cadence should be considered part of the manoeuvre score for the obstacle. Natural ranch horse appearance will also be valued ranging from plus 1 ½ to minus 1 ½. Manoeuvre evaluations and penalty applications are to be determined independently.

Natural ranch horse appearance will be evaluated ranging from plus 1 ½ to minus 1 ½.

The following penalties will be applied to each occurrence and be deducted from the final score.

One (1) point

- Over-bridled (per manoeuvre)
- Out of frame (per manoeuvre)
- Each hit, bite or stepping on a log, cone plant or any component of the obstacle
- Incorrect or break of gait at walk or trot for two (2) strides or less
- Both front or hind feet in a single-stride slot or space at a walk or trot
- Skipping over or failing to step into required space
- Split pole in lope-over
- Incorrect number of strides, if specified

- One to two steps on mount/dismount or ground tie except shifting to balance
- Wrong lead or out of lead for two (2) strides or less

Three (3) points

- Wrong lead or out of lead for more than two (2) strides
- Draped reins
- Break of gait at lope, except when correcting an incorrect lead
- Break of gait at walk or trot for more than two (2) strides
- Three to four steps on mount/dismount on ground tie
- Trotting for more than three (3) strides in lope departures or exiting a rollback into a lope from a stop or walk
- Knocking down or over, or severely disturbing an obstacle
- Stepping out of or falling off an obstacle with one (1) foot
- Missing or evading part of a log/obstacle with one (1) foot

Five (5) points

- Spurring in front of cinch
- Blatant disobedience
- Use of either hand to instil fear
- Stepping out of or falling off an obstacle with more than one (1) foot
- Missing or evading part of a log/obstacle with more than one foot
- Dropping an object required to be carried
- 1st or 2nd cumulative refusal
- Letting go of gate
- Five or more steps on mount/dismount or ground tie

Off-Pattern (OP) - Exhibitors cannot place above others who complete pattern correctly.

- Incomplete manoeuvre
- Eliminating or adding a manoeuvre
- 3rd refusal
- Repeated blatant disobedience, and failure to dally and remain dallied
- Use of two hands (except horses shown in a snaffle bit/hackamore),
- more than one finger between split reins or any fingers between romal reins (except in the two-rein)

- Failure to open and shut gate, or failure to complete gate

Disqualified 0 – Score

- Lameness
- Abuse
- Leaving working area before pattern is complete
- Illegal equipment
- Disrespect or misconduct
- Improper Western attire
- Fall of horse/rider

3.7 RANCH REINING;

The ranch reining class measures the ability of the ranch horse to perform basic handling manoeuvres with a natural head carriage in a forward-looking manner. The ideal ranch reining horse should have a natural ranch horse appearance from head to tail in each manoeuvre. Patterns may be chosen from any of the ranch reining patterns or approved by the show management and Judge.

3.7.1 CREDITS AND PENALTIES

All runs begin upon entering the pen and any infractions are subject to penalty at that time such as two hands on the reins, using either hand to instill fear or praise, etc.

To rein a horse is not only to guide him but also to control his movement. The best reined horse should be willingly guided or controlled with little or no apparent resistance. All deviations from the exact written pattern must be considered a lack of or temporary loss of control and therefore a fault that must be marked down according to severity of deviation. The horse/rider team's overall performance should be credited for smoothness, finesse, attitude, quickness, and authority of performing various manoeuvres while using controlled speed which raises the degree of difficulty and makes the horse/rider team more exciting and pleasing to watch.

Natural ranch horse appearance will be evaluated ranging from plus 1 ½ to minus 1 ½.

One-half (1/2) point:

- Starting a circle or exiting a roll-back at a trot for up to two (2) strides;
- delayed change of lead by one stride where the lead change is required by the pattern description;

- failure to remain a minimum of 6 metres from the wall or fence when approaching
- a stop and/or roll-back;
- over-spin or under-spin up to 1/8 turn.

1 point:

- Over-bridled (per manoeuvre)
- out of frame (per manoeuvre)
- out of lead in the circles, figure eights or around the end of the arena (this penalty is cumulative and will be deducted for each quarter of a circle the horse is out of lead).
- Over or under spinning 1/8 to 1/4 turn.
- Slipping rein.

2 point:

- Break of gait; including executing a simple lead change where pattern asks for 'change of lead'
- freeze up in spins or roll-backs;
- failure to stop or walk before executing a lope departure on trot-in patterns;
- failure to be in a lope prior to the first marker on run-in patterns;
- failure to completely pass the specified marker before initiating a stop position
- trotting beyond two strides, but less than 1/2 circle or 1/2 length of the arena;
- at end of pattern, failure to hesitate to demonstrate completion of pattern.

5 point:

- Spurring in front of cinch;
- blatant disobedience;
- use of either hand to instil fear;

Off-Pattern (OP):

- breaking pattern;
- inclusion of manoeuvre (e.g. over or under-spinning, backing more than two (2) strides, etc.);
- trotting in excess of 1/2 circle or 1/2 length of the arena;
- repeated blatant disobedience;
- use of two hands (except horses permitted in a snaffle or hackamore)

- more than one finger between split reins or any fingers between romal reins (except in the two-rein).

Exhibitors cannot place above others who complete the pattern correctly.

Disqualification (DQ):

- Lameness
- abuse
- leaving working area before pattern is complete
- illegal equipment
- disrespect or misconduct
- improper Western attire
- fall of horse/rider;
- out of control, dangerous, or excessive schooling.

3.8 RANCH CONFORMATION

The purpose of ranch conformation is to preserve the ranch horse type, by selecting well-mannered horses in the order of their resemblance to the breed ideal and that are the most positive combination of balance, structural correctness, and movement with appropriate breed and sex characteristics and adequate muscling. The ideal Ranch conformation horse should have a natural ranch horse appearance from head to tail.

- a) The Ranch conformation class must be held after the conclusion of the other events. Excluding Ranch Prospect Conformation which is held after the Ranch Prospect Lungeline and Ranch Prospect Trail classes.
- b) To be eligible to compete in the Ranch Conformation class the horse must be shown in at least
- c) one ridden class in division on the day of the show.
- d) Stallions, geldings, and mares are exhibited in the same class. Exception: Youth – geldings and mares only.
- e) Horses are to be shown in a good plain working halter, rope, braided, nylon or plain leather. Horses will walk to the Judge one at a time.
- f) As the horse approaches, the Judge will step to the right to enable the horse to trot straight to a cone placed 15 m away. At the cone, the horse will continue trotting, turn to the left and trot toward the left wall or fence of the arena. After trotting, horses will be lined up head to tail for inspection by the Judge. Horses that fail to trot after 3 attempts will be

disqualified. Judges may ask a competitor to trot their horse again if inadequate distance or soundness is at question.

- g) The Judge shall inspect each horse from both sides, front and rear and place the horses in order of preference.

3.8.1 PRESENTING ADDITIONAL HORSES

You can have another person present your additional horse in a Ranch Conformation class, provided certain requirements are met.

- a) Qualified member (such as an Amateur or Youth) can show additional horses for you in Ranch Conformation, provided club or RHAA membership is held.
- b) Trainer/Helper: If you are showing multiple horses in an open class, you can have a trainer or helper handle the additional horse, provided club or RHAA membership is held.

3.9 CATTLE CLASSES (GENERAL):

3.9.1 CUTTING & ROPING

Removing a cow from the herd after the first horse has worked may only be done when it is in the best interest of human or animal welfare. Such decision to remove a cow shall be made by the show management or its representative.

Examples:

- a) At any time, a cow leaves the herd and subsequently endangers the rider, the helping horses, or other contestants. Ruling: The cow will be removed from the arena.
- b) A cow leaves the herd several times and does not challenge or endanger any other animal or human being. Ruling: The cow will remain in the arena.
- c) A blind or crippled cow is found in the herd. Ruling: The show management or representative may or may not rule that a blind or crippled cow be removed at any time.
- d) A wild cow voluntarily leaves the working area. Ruling: At the discretion of show management or class representative, the wild cow does not have to be returned to the herd

3.9.2 COW WORK & BOXING

Awarding New Cows:

- a) The awarding of a new cow is the sole decision of the Judge and is only intended in the event of an unworkable animal. Judges will signal for a new cow with two blasts of a whistle, horn or walkie talkie.
- b) A new cow is only given if the current cow is considered unworkable by leaving the arena working floor or unworkable for not allowing the contestant to exhibit his/her horse to any extent. Examples of this are animals that immediately fight the contestant's horse or enter the arena and refuse to move.
- c) Under no circumstances will a new cow be awarded if it is the contestant's fault that the cow is tired, out of air, run down or overworked to the point he doesn't care to move, etc.
- d) Judges will signal for a new cow with two blasts of a whistle or horn.

If two cows have been awarded and a third is necessary, the contestant has the option to be moved to the last draw of the class to complete their cow work. If you are the last draw of the class, then you will have the option to be first following the drag of the next class or 20 minutes after the completion of your class if you are the last class of the day.

3.10 RANCH CUTTING;

This class is Judged on the ability of the horse to work a cow by separating it from the herd and holding it to demonstrate the horse's ability to work the cow. A single cow is cut from the herd, and the horse must demonstrate its ability to work the cow. The ideal ranch cutting horse should have a natural ranch horse appearance from head to tail in each manoeuvre.

Objective is to cut two cows from the herd and work the cow(s) with the assistance of two turn-back riders and two herd holders.

Show Management may supply two herd holders and two turn back riders, or exhibitors may supply their own helpers. If an exhibitor is a herd holder or turn back rider, he or she may use the horse that they are competing on or use a different horse. NB: Announcer to notify when one (1) minute remaining.

There will be a two-minute time limit. Each exhibitor must work two head and has the option of ending their run before the two-minute limit or working the full two minutes. Working more or less than two cows will incur an Off Pattern (OP) score.

- a) Time will begin when a rider crosses a pre-determined and marked timeline prior to entering the herd. The rider will then quietly separate his/her cow from the herd.
- b) Unnecessary roughness or disturbing the herd excessively could result in disqualification.
- c) Ultimate credit will be given to the horses demonstrating excellence in the herd work by committing to, driving, setting up and working a cow in the centre of the arena with minimal disturbance to the herd.
- d) Horses will not be penalised for reining during the cutting portion but should display natural ability.

Scoring: 100 percent will be Judged by the horse's ability and performance.

Penalties will be assessed as follows:

1 Point

- over-bridled (per manoeuvre)
- out of frame (per manoeuvre)
- losing working advantage
- working out of position

3 Points

- cattle picked up or scattered
- spurring on shoulder
- pawing or biting cattle
- back fence
- hot quit.

5 Points

- horse quitting cow
- losing cow
- changing cattle after a specific commitment
- failure to separate a single animal after leaving the herd
- blatant disobedience.

Off Pattern (OP)

- turn tail
- failure to cut two cows

- repeated blatant disobedience
- use of two hands (except horses shown in a Snaffle bit/Hackamore or where division specific gear rules apply)
- more than one finger between split reins, open fingers, or any finger/s between romal reins (except in the two–rein).

Disqualification (DQ)

- Excessive disturbance of herd to the point that the exhibitor is asked to leave the arena
- lameness
- abuse
- illegal equipment, improper Western attire
- disrespect or misconduct
- leaving working area before run is complete
- fall of horse/rider
- out of control, dangerous, or excessive schooling

3.11 RANCH BOXING

Boxing consists of single cow work (boxing) on the end of the arena. The goal of this class is to introduce the rider to the “boxing” phase of the cow work. Judging begins when the contestant enters the arena.

There will be no schooling between cows if a new cow is awarded. Each contestant upon receiving a cow in the arena will hold that cow on the prescribed end of the arena for fifty (50) seconds, demonstrating the ability of the horse and rider to control the cow. It is legal to hold the reins and Romal in one hand (rein hand) while boxing the cow. Time will begin when the gate closes behind the cow after being let into the arena. The Announcer or Judge will signal the completion of the fifty (50) seconds with a whistle or horn.

Scoring will be based on 60 – 80, with 70 denoting an average performance. The Judge may blow the whistle at any time to terminate the work. A disqualification (DQ) will be given if the work is not complete at that time. Each work will be limited to 50 seconds and, the Judge may request additional work at his/her option.

The Show Manager may appoint a “help horse and rider” for cattle events to assist with removing cattle from arena once run is completed.

Credits

- maintaining control of the cow always
- maintaining proper position
- degree of difficulty
- eye appeal
- timed worked.

Penalties are to be assessed, per occurrence, as follows for the boxing/cow work:

1 point

- loss of working advantage
- working out of position.
- Excessive hollering

3 points

- loss of control and cow leaves end of arena.

5 points

- spurring or hitting in front of cinch at anytime
- blatant disobedience defined as kicking, biting, bucking, rearing, striking or obviously insubordinate.

DQ (Disqualification)

- turn tail
- Open competitors, using two (2) hands on the reins in a bridle or the two-rein
- balking
- out of control
- bloody mouth
- illegal equipment
- leaving work area before run is complete
- schooling between cows if new cow is awarded
- failure to quit working a cow after a new cow has been awarded

3.12 RANCH ROPING

Exhibitors are permitted to hold romal and tail in one hand. If exhibitor chooses to show this way they must enter the arena with reins in one hand and are not allowed to touch rein with the offhand at any time during the class. Exhibitor may show in romal, split or one-piece reins. No tie-downs or martingales etc. may be used in this class.

- a) The intent of this class is to show the ability of the horse and rider skill of handling cattle as if they were doctoring injured or sick cattle. Cattle should be handled as calmly and slowly as possible. The Judge should Judge this class as if the cattle belonged to him or her. Entry does not have to separate their cow from herd and should not receive credit for separation from herd. When cow is separated from the herd there should be no excessive running or cutting of the cow.
- b) This is a Judged event with a 90 second time limit. Scoring is from 0 – 100, 70 denotes an average score. The rope must be thrown, and the contestant may throw only two loops. Any attempt by exhibitor to trap, snare, or collar cow by holding onto the loop will be cause for disqualification. A second rope may be used, but the total number of loops thrown may not exceed two (2). If a second loop is used it must be recoiled. The Honda on the rope used must be of a factory plastic breakaway design.
- c) Horse and rider must start from behind a starting line which will be located 1/3 of the arena length away from where ten (10) calves are held as a herd with each bearing a number 0 – 9. A random draw will be used to select the calf to be roped and will be announced to the contestant when the horse crosses the starting line.
- d) Each contestant may have the option of using one (1) herd holder. The herd holder may cross the starting line. The sole duty of the herd holder is to assist in holding the cattle at the working end of the arena.
- e) The contestant must make a legal catch of the designated calf and dally up. A legal head catch is a loop that goes completely over the calf's head and honda can be broken by any part of the calf's body but must go over the calves headfirst. When the calf breaks free from honda, the Flag Judge will signal the end of the run.
- f) In youth division classes, only the youth exhibitor at their discretion may have their ropes tied to the saddle horn instead of dallying or they may dally.

- g) After catching, it is desired for the horse to remain facing the cow until the honda breaks. Turning away from the cow to make the honda break quicker will receive a 5-point penalty.

CREDITS

- Quietness in the herd.
- Handling the cattle.
- Position of the horse when cattle are roped.
- Facing to cow.
- Quality of loop.

Off Pattern (OP)

- Failure to make a legal head catch

DISQUALIFICATIONS:

- Running into or over cattle.
- Schooling.
- Whipping or hitting horse with rope.
- Half of herd crossing starting line.
- Thrown from horse.
- Fall to ground horse and/or rider
- Loss of rope.
- Roping the wrong cow/number or multiple cows.

PENALTIES:

1 Point; Holding beast too long without roping.

3 Points; Breaking the Honda without a dally.

5 Points

- Missing 1st loop
- Excessive running/scattering of herd.
- Blatant disobedience including kicking, biting, bucking, rearing, or striking.
- Horse turns tail.
- Turning away from the cow to make honda break quicker.

3.13 RANCH COW WORK

The ideal Ranch horse must also be a cow horse, and this class demonstrates and measures the horse's ability to do cow work. Holding the saddle horn is permitted. There is a time limit per exhibitor to perform the work depending on the division and the time begins when the cow is turned into the arena. If the time has not elapsed and the Judge is satisfied that all requirements of the class have been met, the Judge should blow the whistle for the exhibitor to cease work. The Judge may blow a whistle at any time for the exhibitor to cease work for safety reasons. Judges will give credit for what they have seen. Only the Judge may award a new cow to a contestant to replace a cow that will not honour a horse. If the Judge awards a new cow, the exhibitor has the option to refuse the new cow by continuing to work. If the exhibitor accepts the new cow, the time for working the cow will start over. If the exhibitor intends to accept the new cow, the exhibitor must pull up immediately. When multiple Judges are scoring, any one of the Judges may terminate the work or signal for a new cow.

- a) The same horse and rider combination CANNOT enter both Ranch Cow Work and Limited Ranch Cow Work.
- b) The Show Manager may appoint a "help horse and rider" for cattle events to assist with removing cattle from arena once run is completed.

Time Limits

- c) All divisions are allotted three (3) minutes to complete the work.
- d) When there is one (1) minute left, the announcer will announce, "one minute remaining". At end of allotted time the announcer will call "time".

There are three (3) parts to the class:

- boxing
- fence work
- roping or circling.

PART ONE: Boxing the Cow: The rider shall ride into the arena, face the cattle entry gate and signal for their cow to be turned into the arena. The cow shall be controlled on the entry end of the arena for enough time to demonstrate the horse's ability to hold the cow. If the cow does not immediately challenge the horse, the rider shall aggressively move in on the cow to demonstrate his horse's ability to drive and block the cow on the entry fence.

PART TWO: Fence Work: After the cow has been controlled on the entry end of the arena, the rider shall set the cow up and drive it down either side of the arena. The

cow should be turned on the fence at least once in each direction. The first run for a turn shall be past the half-way mark of the arena. All turns down the side shall be completed before reaching the end fence.

PART THREE: Roping or Circling:

The exhibitor has the option of circling the cow in the middle of the arena in both directions in lieu of roping. An amateur or youth exhibitor may circle or rope the cow but cannot combine the two to get credit for this portion of the run.

To rope the cow, the exhibitor must be carrying a rope when the run starts. The exhibitor may pull up after the fence work, take down the rope and proceed to rope and stop the cow. The exhibitor must then rope the cow and bring it to a stop. In the roping portion of the class, two (2) throws are permitted, and the horse will be Judged on two (2) manoeuvres: tracking/rating and stopping the cow. It is not necessary that the exhibitor catch to receive a score in the roping portion. The catch is legal if the cow looks through the loop and the rope pulls tight on any part of the animal. The rope may be tied on or dallied.

Circling the cow. The exhibitor will manoeuvre the cow smoothly at least 360° in each direction without interference from the fence. The circle's size, symmetry, speed, and relative balance from right and left show control. Tightening the circles down with fast head- to-head speed will be a credit situation. The circles should be completed before the cow is exhausted. Once an exhibitor has committed to circling a cow, if the cow falls no new cow will be awarded. The exhibitor will complete the run by riding around the fallen cow to fulfil circling requirements. In the circling portion of the judging, one whistle will terminate the work, and two whistles will award a new cow.

Credits – All runs begin upon entering the pen, any infractions (such as two hands on the reins, using either hand to instill fear or praise, etc.) are subject to penalty at that time.

Credit will be given:

Boxing: for the horse's expression and its 'cow sense' (i.e., making moves with little rider assistance). holding, controlling, and turning the cow. amount of work done. and the degree of difficulty of the work.

Fence Work: for making the first run past the centre of the arena. making turns right on the cow. and controlling a difficult cow.

Roping: for rating and following cow to allow rider the optimal roping position.

stopping hard. and staying in the ground during the hold. Credits for each element of Roping range from minus 1½ to plus 1½.

Circling: when the horse works willingly. acknowledges the cow. and gets close enough to the cow to control the circles. Credits for Circling range from minus 1½ to plus 1½ points for each direction.

Penalties will be assessed as follows:

1 Point

- over-bridled (per manoeuvre)
- out of frame (per manoeuvre)
- loss of working advantage
- using the corner or the end of the arena to turn the cow when going down the fence
- changing sides of arena to turn cow
- for each length horse runs past cow
- working out of position
- slipping rein
- failure to drive cow past middle marker on first turn
- two-loop catch in amateur and Youth classes.

2 Points

- going around the corner of the arena before turning cow
- when working an animal in the open field (at least 6 m from the side of arena) and the animal gets within 1 m from the end fence before being turned
- failure to catch if roping in amateur and Youth classes.

3 Points

- exhausting or overworking the cow before circling or roping
- hanging up on the fence (refusing to turn)
- knocking down the cow without having a working advantage
- two-loop catch when roping in open class.

5 Points

- failure to turn the cow both directions on the fence
- spurring in front of cinch
- blatant disobedience
- use of either hand to instil fear
- an illegal catch (loop fails to pass over head or pulls tight on tail only)
- Failure to catch when roping in open classes

Off-Pattern (OP)

Cannot place above others who complete pattern correctly.

- Turning tail
- failure to attempt any part of the class
- repeated blatant disobedience
- schooling after entering the arena prior to calling for cow
- schooling horse between cows if new cow is awarded
- Complete loss of rope in open classes
- use of two hands (except horses shown in a Snaffle bit/Hackamore or where division specific gear rules apply)
- more than one finger between split reins, or any finger/s between romal reins (except in the two-rein)

Disqualification (DQ)

- bringing the cow straight over backwards landing on its back or head with all four feet in the air
- lameness
- abuse
- illegal equipment, improper Western attire
- disrespect or misconduct
- leaving working area before pattern is complete
- fall of horse/rider

Note: If the open rider runs out of time to rope, there will be no credit for the stop/hold manoeuvre and a 5-point penalty for failure to catch. Riders may still earn credit for tracking/ rating, control/position and speed/ degree of difficulty.

3.14 LIMITED RANCH COW WORK:

The same horse and rider combination CANNOT enter both Ranch Cow Work and Limited Ranch Cow Work.

The Show Manager may appoint a “help horse and rider” for cattle events to assist with removing cattle from arena once run is completed.

Content. Limited ranch cow work exhibitors are allotted one minute and forty-five seconds to complete the work. When there is 50 seconds left, the announcer will announce, “50 seconds remaining”. At one minute and forty-five seconds, the announcer will call for time.

Exhibitors are not required to use all the allotted time but must ride until the Judge whistles the end of the run or time expires, whichever occurs first. There are four parts to the work: boxing the cow. setting up the cow and driving it down the fence to the opposite end of the arena. boxing it at the opposite end of the arena and then driving the cow past the middle marker again. There is no expectation that the exhibitor will make a fence turn, instead the drive down the fence demonstrates correct position and control around the corner.

Part 1; Boxing the Cow --The rider shall ride into the arena, face the cattle entry gate, and signal for their cow to be turned into the arena. The cow shall be controlled on the entry end of the arena for a sufficient amount of time to demonstrate the horse’s ability to hold the cow. If the cow does not immediately challenge the horse, the rider shall aggressively move in on the cow to demonstrate his horse’s ability to drive and block the cow.

Part 2; Set Up Cow, Drive Down Fence to Opposite End of Arena - After the cow has been controlled on the entry end of the arena, the rider shall set the cow up for driving down the side of the arena. When coming out of corner, the horse shall be close enough to cow to demonstrate control with cow against the fence. This distance and control should be maintained for approximately 1/2 to 3/4 the length of arena. Rider will then stop and release the cow and move horse toward centre of arena to set the cow up for boxing.

Part 3: Boxing the Cow at Opposite End of Arena - Boxing the Cow at Opposite End of Arena. Move horse toward centre of arena to set the cow up for boxing. Again, box the cow for a sufficient time to demonstrate the ability of the horse to contain the cow at that end. If the cow does not immediately challenge the horse, the rider shall aggressively move in on the cow to demonstrate their horse’s ability to drive and block the cow on the entry fence.

Part Four – Drive: After a reasonable amount of time, the contestant shall set up and drive/rate the cow down the fence, opposite fence of the Judges, to the opposite end of the arena. When coming out of corner, the horse shall be close enough to the cow to demonstrate control with cow against the fence. This distance and control should be maintained past the centre marker and continue until the Judge signifies the completion of the run or time expires. The rider will then release the cow.

Credits and Penalties.

All runs begin upon entering the pen. any infractions (such as two hands on the reins, using either hand to instil fear, etc.) are subject to penalty at that time. During Boxing, credit will be given for the horse's expression and its 'cow sense' (i.e., making moves with little rider assistance). holding, controlling, and turning the cow. the amount of work actually done. and the degree of difficulty of the work. Credit will be given during Set Up Cow and Drive Down Fence for rating the cow. blocking the cow with pressure towards the end of the arena. driving the cow with control down the side of the arena. and controlling a difficult cow. Manoeuvre evaluations and penalty applications are to be determined independently. The following penalties will be applied to each occurrence and be deducted from the final score:

Penalties will be assessed as follows:

1 Point

- Over-bridled (per manoeuvre).
- out of frame (per manoeuvre).
- loss of working advantage.
- working out of position on first drive
- changing sides on the second drive/rate;
- failure to drive past the middle marker

3 Points

- knocking down the cow without having a working advantage
- losing a cow while boxing.
- Dangerous position
- Performing a fence turn (whether initiated by horse or rider)
- Failure to drive cow past middle marker on second drive before time expires

5 Points

- Spurring or hitting in front of the cinch at any time or excessively whipping or spurring the horse

- blatant disobedience defined as kicking, biting, bucking, rearing, striking, or obviously insubordinate
- running the cow into the back fence with force;
- contestant not in a working position that causes the cow to initiate at least one turn/change of direction on the second boxing phase before crossing the timeline and terminating the work

Off-Pattern (OP)

- Turning tail
- failure to attempt any part of the class
- repeated blatant disobedience
- schooling after entering the arena prior to calling for cow
- schooling horse between cows (if new cow is awarded)
- use of two hands (except horses shown in a Snaffle bit/Hackamore or where division specific gear rules apply)
- more than one finger between split reins, open fingers, or any finger/s between romal reins (except in the two–rein).
- On first drive down fence, failure to drive cow past middle marker after two attempts.

Exhibitors cannot place above others who complete the pattern correctly.

Disqualification (DQ)

- lameness, abuse
- illegal equipment
- improper Western attire
- disrespect or misconduct
- leaving arena before run complete
- fall of horse/rider.
- out of control, dangerous, or excessive schooling.

3.15 RANCH PROSPECT LUNGELINE

Yearlings, 2&3 year olds only

The purpose of showing a horse on a lunge line is to demonstrate that the horse has the movement, manners/expression/attitude, and conformation to become competitive under saddle.

This class defines what it means to be a “Ranch Prospect”. Yearlings are not expected to demonstrate the behaviour or quality of a finished show horse, but only that performance necessary for a reasonable presentation to the Judge. Therefore, the purpose of this class is to reward quality of movement, manners, expression, attitude, and conformation suitable to future performance and the horse is to be Judged with its suitability as a future Ranch horse under saddle in mind.

3.15.1 CLASS FORMAT

The class consists of two (2) sections and must be Judged in the following order;

First Section

- a) Conformation/Equipment Inspection – Each horse is to be inspected by the Judge on conformation, proper equipment and for evidence of abuse and inhumane treatment. Each exhibitor will walk into the arena to the Judge and halt for evaluation.
- b) Horses will then trot off straight and around a cone and take a place on the wall inside the arena.
- c) All entries will be inspected in this fashion and as the “trot-off” is administered, horses showing levels of lameness will be excused from the class at that time.

Second Section

Lunging Demonstration – The Judge will stand outside the lunging circle.

- a) The lunging demonstration will begin at the sound of a whistle or other audible indicator when the horse has reached the perimeter of the circle. Time will not begin before the horse reaches this perimeter.
- b) When the “begin” signal is given, the exhibitor will be allowed 1½ minutes to present the horse at all three (3) gaits in both directions.
- c) At the end of the 1½ minutes, the signal will be given to signify the end of the demonstration. Show management has the option of adding a “half-way” signal if they choose.
- d) At the completion of their 1½ minutes the entry will retire from the lunging area and walk to the end of the arena. The horses are to stand quietly on the

wall, whilst the other exhibitors present their horses. Exhibitors can begin work in the direction of their choice (counter or clockwise).

Equipment

- a) Horses are to be shown in a simple leather, rope or nylon working halter and lunge line.
- b) For the lunging demonstration, the only attachment allowed to the halter is the lunge line. Lead (leather, nylon, soft rope or mecate) is attached with a clip or leather strap to be fastened to the halter underneath the jaw of the horse. The use of a lunge whip is permissible
- c) Minimum length of the lead to be six (6) metres and must not exceed nine (9) metres.
- d) The lunge line must hang free from the halter without touching any part of the horse.
- e) No other equipment is allowed on the horse during the class. Mechanical or retractable lunge lines are not permitted.
- f) Only movement, manners/expression/way of going and conformation are being Judged.

Attire

Conventional Western attire is mandatory. The type of attire worn by the exhibitor is not to be a consideration in placing the horse if the attire meets the requirements stated above.

Additional Exhibit

An exhibitor can show more than one (1) horse in a class providing the same handler exhibits the horse in both parts. The exhibitor must have a handler correctly attired for this class, to hold any additional exhibit in the arena while awaiting finalisation of the class. The handler must be correctly attired and a current financial member of the affiliated club, the AQHA or RHAA.

Movement

Judges are to evaluate movement based on the following gaits.

- a) Ordinary Walk – The Ranch horse ordinary walk is straight, square, flat-footed, relaxed. The horse moves freely with no anticipation to move to the next gait.
- b) Trot – The Ranch horse trot is a square two-beat diagonal trot and is steady, soft, and slow enough for riding long distances.

- c) Canter – The Ranch horse lope is a 3-beat gait that is cadenced, straight and steady and is comfortable to ride over long distances. When cantering, the horse must be in the same lead as the direction the horse is traveling.
- d) Stopping position (i.e., both hocks engaged and stopping on the hindquarters). All four feet stop moving before the next manoeuvre is attempted.
- e) Reverse – The horse turns briskly and flat with front feet on the ground and holding an inside rear pivot foot. The reverse may be performed in either direction.

Example: -

If a horse fails to ever demonstrate the correct lead (front and/or rear) either direction it will be scored an Off Pattern (OP)

Use of the circle

Consideration will be given to how well or how poorly the horse/exhibitor team uses the 7.5 m radius of the lunging circle. A separate box on the scorecard is available to indicate an overall score for use of the circle, using a scale between +1 ½ & - 1 ½

Scoring

Judges are to evaluate movement based on the gaits. Plus & minus scores reflect the smoothness, finesse, attitude, movement, and manners when performing the various manoeuvres. Multiple penalties may be incurred per manoeuvre.

- a) **Conformation** will be scored using a scale between +3 & -3. The horse will be Judged on conformation suitable to future performance as a Ranch Horse competitor. The Judges are to look for a total picture, emphasizing balance, structural correctness, and athletic capability.
- b) **Walk in each direction.** Scored using a scale between +1 ½ & - 1 ½. The horse must be walked long enough for the Judge to have enough time to evaluate and score the walk. The change of direction turnaround at the walk may count for the second walk score on the official score sheet. Lower gait scores should reflect stumbling in the gait.
- c) **Trot in each direction.** Scored using a scale between +3 & -3 Using a 7.5 m radius, the horse is to trot a minimum of half (½) a circle both directions of the ring. Lower gait scores should reflect stumbling in the gait.
- d) **Lope or Canter in each direction.** Scored using a scale between +3 & -3 the horse is to lope or canter a minimum of one (1) full circle both directions of the ring.
- e) Any entry that fails to demonstrate the correct lead for one (1) full circle, or is disunited throughout the lope or canter, will receive an OP (off pattern) and

cannot place over another entry that has demonstrated the correct lead in its entirety. Lower gait scores should reflect stumbling in the gait.

- f) **Use of Circle** – Scored using a scale between +1 ½ & - 1 ½. Scores for all gaits in both directions should reflect positive, consistent use of the radius of the circle. Extra credit will be given for full, extended use of the circle on a slightly loose line. Lower gait scores should reflect lack of full use of the circle.
- g) **Manners/Expression/Attitude**–Scored using a scale between +3 & -3. Horses will be penalised for obvious signs of overwork and sourness such as ear–pinning, head–throwing, striking, tail wringing, or a dull, lethargic manner of going.

Horses will also be penalised for dangerous behaviour such as excessive bucking, cutting into the circle, or running off. Additionally, incidental touching the horse with the whip, cross–cantering, balking, backing up on the lunge line and excessive urging from the exhibitor will be penalised accordingly

Scoring of the Circle

It is the Judge's responsibility to evaluate the circles and incorporate use of the circle in the gait scores based on the following scale:

- horse consistently stays on the perimeter of the circle with slight looseness in the line. Horse turns around on the circle perimeter
- horse is only slightly inconsistent in using the 7.5 m radius of the circle
- horse is shown in a circle radius of less than 7.5 m
- potentially dangerous slack in the line
- horse pulls exhibitor out of the circle.

Penalties

5-point Penalty per direction:

- failure to walk a minimum of ¼ circle
- failure to trot a minimum of a quarter of a circle
- failure to demonstrate the correct lead, for a minimum of a quarter of a circle
- use of either hand to instil fear.
- blatant Disobedience

Off Pattern OP

- failure to show at all three gaits in both directions

- Horse fails to canter on the correct lead, or is disunited one or both ways in the canter circle
- Failure to ever demonstrate correct leads &/or gait as designated

Disqualification DQ:

- evidence of lameness the Judge will immediately excuse horse from the arena.
- blatant striking horse with the whip during the lunging demonstration that will cause forward or lateral movement
- fall to the ground by horse. A horse is deemed to have fallen when its shoulder and/or hip and/or underline touches the ground
- horse steps over or becomes entangled in the lunge line
- improper equipment, evidence of abuse, or other violation of RHAA rules
- exhibitor shows disrespect towards the Judge
- anytime the horse becomes detached from the handler
- failure to complete trot off for soundness in three attempts

3.16 RANCH PROSPECT TRAIL

Yearlings, 2&3 year olds only

Mandatory obstacles

Choose three (3) from this list and at least three (3) different other obstacles are to be selected from the list of optional obstacles:

- a) Opening, passing through and closing gate. Use a gate that does not endanger horse or handler. Must be left hand push away gate.
- b) Horse must go over at least four (4) logs or poles. These can be in a straight line, curved or zig zag.
- c) Backing obstacles to be spaced a minimum of 70cm apart. Back thru L Shape, V shape, U shape or similar shape.

Optional Obstacles, but not limited to:

- back through and around at least three (3) markers. Minimum recommended ground space 70cm.
- lead horse over wooden bridge. Suggested minimum width 90cm, suggested minimum length 1.8m, maximum height from ground to top of bridge 30cm. Bridge must be sturdy, safe, without sides and negotiated at the walk only.
- serpentine obstacles at walk and/or trot. Suggested spacing of 1.1m or 1.5m for trot.

- carry object from part of the arena to another (only objects that reasonably might be carried on a trail ride can be used).
- put on and remove slicker.
- remove and replace materials from mailbox.
- side pass – diameter of pole suggested maximum height of 15cm.
- an obstacle consisting of 4 poles each 1.5 to 2m long, laid in a square. Each contestant will enter the square by walking over pole as indicated. When all four feet are in the square, horse is to execute a turn as indicated and depart.
- a circle to walk/trot in. Approximately 6m in diameter to be marked out, with four (4) cones or similar safe objects.
- any other safe and negotiable obstacle which could reasonably be expected to be encountered on a trail ride and meets the approval of the Judge can be used.
- a combination of one or more of the obstacles is acceptable.

Prohibited Obstacles

- tarps
- water obstacles
- pvc pipe used as a jump or walk over
- tyres
- rocking or moving bridges
- logs elevated in a manner that permits such to roll in a dangerous manner
- painted logs.

Scoring

The exhibitor is scored on the quality of each manoeuvre:

Excellent +1½. Very Good +1. Good +½. Correct 0. Poor -½, Very poor -1, Extremely poor -1½.

- Pluses and minuses reflect the smoothness, finesse, attitude, movement, and manners when performing the various manoeuvres.
- Multiple penalties may be incurred per manoeuvre.

Penalties are assessed as follows:

1 Point

- each hit, bite or stepping on a log, cone plant or any component of the obstacle

- incorrect or break of gait at walk or trot for two (2) strides or less
- both front or hind feet in a single-stride slot or space at a walk or trot
- skipping over or failing to step into required space
- incorrect number of strides, if specified

3 Points

- break of gait at walk or trot for more than two (2) strides

5 points

- blatant disobedience
- use of either hand to instil fear
- knocking over/stepping out of or falling off an obstacle
- dropping an object required to be carried
- 1st or 2nd cumulative refusal
- letting go of gate

Disqualification DQ:

- evidence of lameness the Judge will immediately excuse horse from the arena.
- fall to the ground by horse. A horse is deemed to have fallen when its shoulder and/or hip and/or underline touches the ground
- improper equipment, evidence of abuse, or other violation of RHAA rules
- exhibitor shows disrespect towards the Judge
- anytime the horse becomes detached from the handler

Off Pattern (OP)

Exhibitors cannot place above others who complete pattern correctly.

- incomplete manoeuvre
- eliminating or adding a manoeuvre
- breaking pattern
- 3rd refusal
- repeated blatant disobedience

3.17 RANCH PROSPECT CONFORMATION

Yearlings, 2&3 year olds only

The purpose of ranch conformation is to preserve the ranch horse type, by selecting well-mannered horses in the order of their resemblance to the breed ideal and that are the most positive combination of balance, structural correctness, and movement with appropriate breed and sex characteristics and adequate muscling. The ideal Ranch conformation horse should have a natural ranch horse appearance from head to tail.

- a) The Ranch conformation class must be held after the conclusion of the Ranch Prospect Lunge line and Ranch Prospect Trail.
- b) To be eligible to compete in the Ranch Conformation class the horse must be shown in at least one other Prospect class in division on the day of the show.
- c) Stallions, geldings, and mares are exhibited in the same class. Exception: Youth – geldings and mares only.
- d) Horses are to be shown in a simple leather, rope or nylon working halter.
- e) Horses will walk to the Judge one at a time.
- f) As the horse approaches, the Judge will step to the right to enable the horse to trot straight to a cone placed 15 m away. At the cone, the horse will continue trotting, turn to the left and trot toward the left wall or fence of the arena. After trotting, horses will be lined up head to tail for inspection by the Judge. Horses that fail to trot after 3 attempts will be disqualified. Judges may ask a competitor to trot their horse again if inadequate distance or soundness is at question.
- g) The Judge shall inspect each horse from both sides, front and rear and place the horses in order of preference.

SECTION 4 – GEAR, ATTIRE, EQUIPMENT

4.1 GEAR

4.1.1 EQUESTRIAN WITH DISABILITIES (EWD)

Equipment is to conform to the needs of the exhibitor and be suitable for the horse. Special adaptive equipment may be used where appropriate

4.1.2 LEVEL 1 GREEN

- a) Any age horse to be ridden two-handed in a snaffle bit or hackamores only.
- b) Any 'safe' saddle, with the exclusion of bareback pads. Includes. English, Western, stock or fender saddles.

4.1.3 LEVEL 2 INTERMEDIATE

- a) Any age horse may be ridden two-handed in a snaffle bit or hackamore, or one or two-handed in a curb bit.
- b) Any 'safe' saddle, with the exclusion of bareback pads. Includes. English, Western, stock or fender saddles.
- c) Cattle events must be ridden in Western, stock or fender saddles ONLY.

4.1.4 LEVEL 3 HERITAGE SNAFFLE BIT

Any age horse may be ridden two-handed in a snaffle bit only. Stock or fender saddle may be used, no Western saddles.

4.1.5 LEVEL 4 OPEN

- a) Western saddles compulsory.
- b) Junior horse: 3 to 5 years. Horse's five-years-old (5) and younger may be shown in a Snaffle bit, Hackamore, curb bit, half-breed or spade bit in split reins or *two rein
- c) Senior Horse: 6 years and over. Horse's six-years (6) and older can only be shown in a curb bit, spade or half-breed in split reins, romal, spade bit or *two rein
- d) Two rein: The use of two-rein equipment is allowed in all ranch events for one year only. ***The two rein is used in transitioning horses into the bridle and may be used in all ranch classes. Horses that have been shown in a bridle are ineligible to compete in a two rein.**

4.2 ATTIRE

4.2.1 WESTERN ATTIRE MANDATORY (ALL COMPETITORS)

- a) long sleeve collared shirt (half or full button or zipper) (Collar = band, stand-up, tuxedo etc.)
- b) Western hat (the hat must be on the rider's head when the exhibitor enters the arena) or ASS approved safety helmet. Safety standard numbers for these helmets are AS-NZS 3838, ARBHS 2012 and ASTM F1163.
- c) Western pants/jeans
- d) Western boots.

4.2.2 OPTIONAL ATTIRE

Spurs, chinks, and chaps in ridden classes.

4.3 EQUIPMENT

All rules pertaining to this section of the Rule Book, and any supplementary rules, will be implemented by the approved show committee and if required the Association.

- a) **Hackamore** is the use of a flexible, braided rawhide or leather, or rope bosal, the core of which can be either rawhide or flexible cable. A Hackamore must use a complete Mecate rein which must include a tie-rein. Absolutely no rigid material is permitted under the jaws, regardless of how padded or covered. Horsehair bosals are prohibited. This rule does not refer to a so-called mechanical Hackamore.
- b) **Two Rein.** The purpose of the two-rein option is the transition between the hackamore and bridle and can be used on any aged horse all ranch events for one year only. The bit and bosal combination must be approved in accordance with the following. Only one hand may be used on the reins and hands must not be changed. Any number of fingers between reins will be permitted. Both mecate and bridle reins are to be held in the rein hand. When using two rein equipment, bosals may be of any size, constructed of braided rawhide or leather and have a nonmetal flexible core. No iron or foreign substance may be used. The rider must use one hand on the reins. Fingers between the reins will be permitted.
- c) **Snaffle Bit** means the conventional O-ring, Egg-butt, or D-ring. The diameter of Snaffle bit rings must be a minimum of 50mm and a maximum of 100mm. The bars must be a minimum of 5/16" (8 mm) in diameter, measured one inch (25 mm) in from the cheek with a gradual

decrease to centre of the snaffle. The mouthpiece may be two or three pieces. A three-piece connecting ring 32mm or less in diameter, or a connecting flat bar of 10mm-20mm measured top to bottom with a maximum length of 50mm which lies flat in the horse's mouth is acceptable. The inside circumference of the ring must be free of rein, curb or headstall attachments which would provide leverage. Optional leather strap attached below the reins on a snaffle bit is acceptable.

- d) **Snaffle Bit Split Reins** may be held bridged with the tails of the reins on the opposite side of the neck, crossed & held separately or one rein may be crossed over the neck and held with two hands. **Refer image:**

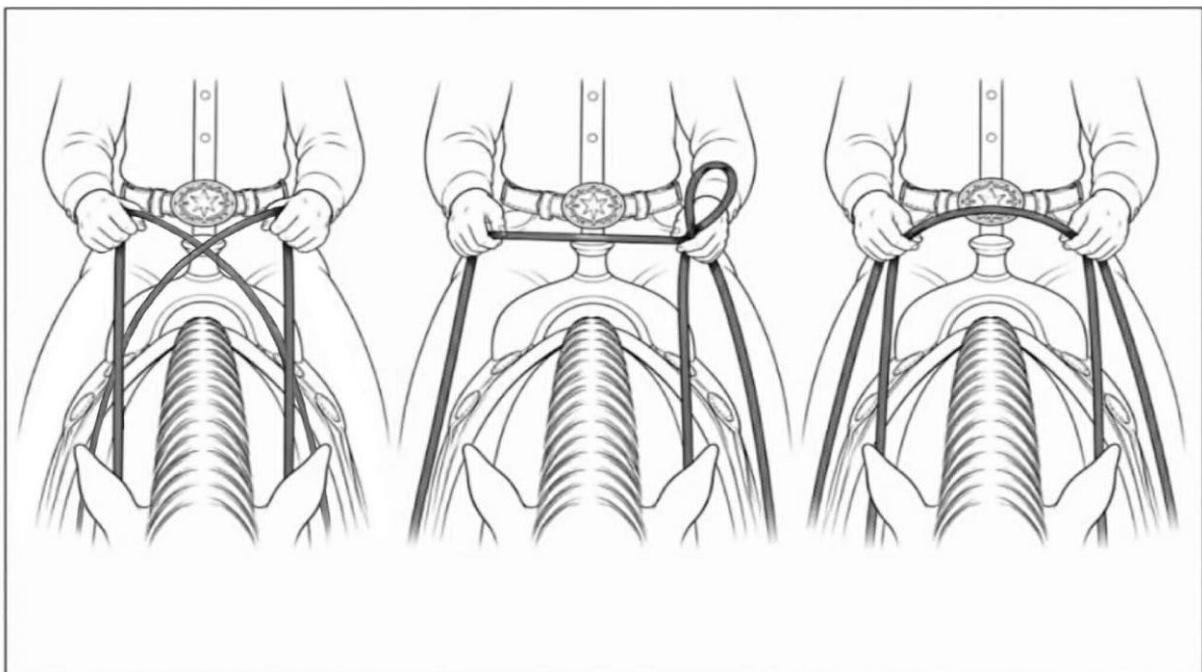

- e) When using a snaffle bit a leather or other woven material chin strap of any width is to be used and should be attached to the bit below the reins. No iron, chain, or other material is allowed. The chin strap can include metal buckles and/or keepers
- f) **Mecate Reins** must run back to the rider or tied to the saddle.
- g) The rider's hands will be carried near the pommel and no further than approximately 50cm apart. Rider's hands must be steady with limited movement. Failure to comply with this rule will result in disqualification.
- h) When riding with a romal, a get-down rope may be used. A get-down rope is defined as a small rope tied around the neck of the horse with a bowline or other non-slip knot and run back to the rider or tied to the saddle. The get-down will be used to lead, ground tie, or tie the horse.

- i) When ground-tying with split reins, one or both reins may be dropped, romal reins may be loosely draped over the horn when used with or without a get-down rope. The get-down rope may also be run through a bosalito, as long as the bosalito is not tight enough to function as a cavesson. If a bosalito is used, it must allow approximately 2 fingers (1 inch) to pass freely between the nose and the bosalito. The bosalito must be constructed of a flexible braided rawhide, leather or rope, the core of which must be flexible.
- j) **Curb Bits** means the use of a bit that has a solid or broken mouthpiece, has shanks and acts with leverage. All Curb bits must be free of mechanical devices and will be considered a legal standard Western bit.
- k) has a shank with a maximum length of 216mm to be measured as indicated in the diagram below;

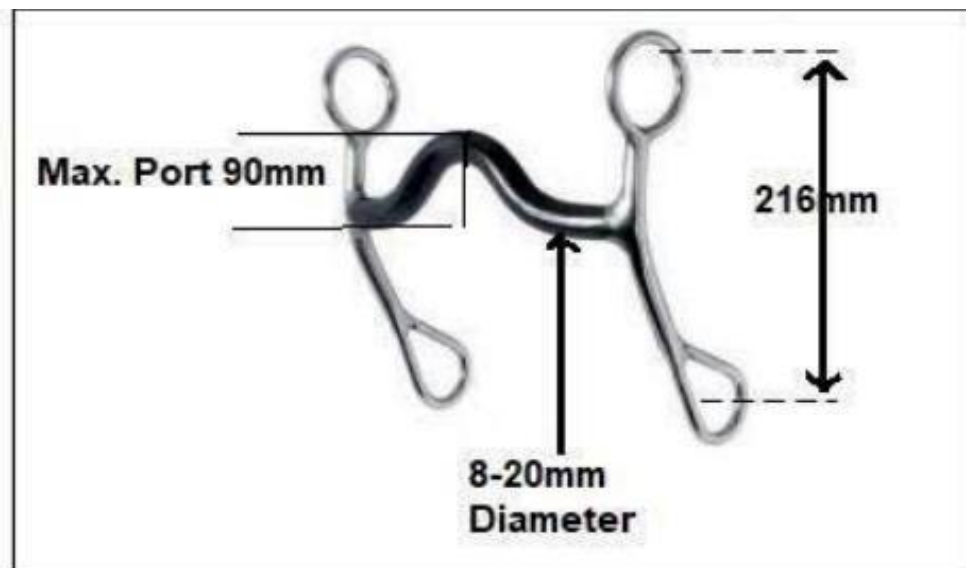

- l) Shanks may be fixed or loose the port must be no higher than 90mm maximum, with rollers and covers acceptable. Broken mouthpieces, half-breeds and spades are acceptable. slip or gag bits, and donut and flat polo mouthpieces are not acceptable when using a curb bit, a curb strap or curb chain is required, but must meet the approval of the Judge, be at least 12.5mm in width and lie flat against the jaw of the horse. A broken strap or chain is not necessarily cause for disqualification.
- m) Mouthpieces – the bars must be round, oval or egg shaped, smooth and unwrapped metal of 8mm to 20mm in diameter, measured 25mm from the cheek. They may be inlaid but must be smooth or latex wrapped. Nothing can protrude below the mouthpiece (bar), such as extensions or prongs on solid mouthpieces than by no more than 1.6mm.

- n) The mouthpiece may be two (2) or three (3) pieces. A three- piece will have a connecting ring of 32mm or less in diameter, or a connecting flat bar of 10mm to 20mm measured top to bottom, with a maximum length of 50mm, which lies flat in the horse's mouth or a connecting roller 10mm to 20mm diameter are acceptable.
- o) Except for Hackamore/Snaffle bit classes or junior horses shown with a Hackamore, only one hand must be used on the reins, and the hand must not be changed, and the index finger only must be between the split reins. Exception: To work a trail obstacle a rider may change hands on the reins, but the index figure only must be between the reins.
- p) Romal means an extension of braided or round material attached to closed reins. This extension shall be carried in the free with a spacing of approximately 40cm between the reining hand and the free hand holding the romal. When using romal reins, the rider's hand shall be around the reins with the wrists kept straight and relaxed, the thumb on top and the fingers closed lightly around the reins. When using romal reins, no fingers between the reins are allowed (except when riding in the two rein). The free hand holding the romal may be used to adjust the rider's length of rein.
- q) Open fingers &/or fingers between the reins is not permitted and will result in an OP (Off Pattern).
- r) The Romal will not be used forward of the cinch or to signal or cue the horse in any way.

Acceptable:

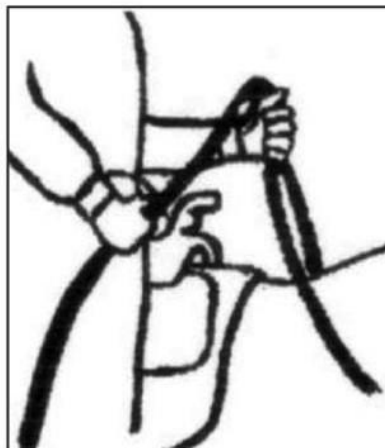

Unacceptable:



4.3.2 PERMISSABLE TACK

- a) Standard mounted Western saddle with horn.
- b) Saddle without a horn is acceptable in the Heritage Snaffle Bit, Green & Intermediate levels.
- c) Horses must be ridden with a bridle having a bit in the mouth or with a hackamore.
- d) Bosal and hackamores shall be of rope or braided rawhide with no metal parts.
- e) Snaffle bit with mecate reins. A continuous rope/hair rein attached to snaffle bit with slobber straps and lead section attached to either rider or saddle.
- f) In Ranch Conformation & Ranch Prospect classes, colts & stallions may use a chain on the lead for safety and control purposes. The chain can be worn under the jaw or through the halter as appropriate but cannot be used over the nose. No lip chains or lip cords permitted.

4.3.3 OPTIONAL EQUIPMENT

- a) Rope or riata. If used, the rope or riata must be coiled and attached to the saddle.
- b) Hobbles attached to saddle.
- c) Tendon Boots, splint boots, bell boots, leg wraps and bandages are allowed in ranch reining & cattle events only.
- d) Tapaderos, except in working cow horse where they are not allowed
- e) Glued on shoes are acceptable in all classes.
- f) Hobbles are permitted when being used in a ground tie
- g) Snaffle bit leather chin strap.
- h) Bosalita constructed of a flexible braided rawhide, leather or rope, the core of which must be flexible. Absolutely no rigid material will be permitted under the jaws, regardless of how padded or covered.

4.3.4 PROHIBITED EQUIPMENT

- Bitless bridles
- Twisted wire bits
- Protective boots, leg wraps, and bandages are prohibited in ranch trail, ranch riding, ranch conformation, ranch on the rail & prospect classes
- Any curb strap narrower than one-half inch
- Chain, wire, or metal tie-down of bonnets are prohibited regardless of how padded or wrapped
- Belly Bands; saw tooth bits; hock hobbles; tack collars; tack curb straps or tack hackamores; war bridles or like devices;
- riding in a curb bit without a curb strap;
- wire or solid metal curb straps no matter how padded;
- wire cavesson; wire or cable tie-downs; bumper bits;
- metal bosals (no matter how padded); chambons; headstalls made of metal (no matter how wrapped or padded), twisted rawhide, or rope may not be used on a horse's head (3/8 inch rope may be used with a slip/gag bit or a bonnet); running martingales used with curb bits used without rein stops; draw reins attached between or around the front legs will not be permitted.

SECTION 5 – GENERAL SHOW RULES

5.1 SHOW RULES

- a) All horses entered must have turned 3 as of 1st August, prior to competing under saddle.
- b) Youth riders must wear an approved safety helmet at all times whilst riding on the Club grounds whether competing or not. Helmets must be ASS approved.
- c) Safety standard numbers for these helmets are AS–NZS 3838, ARBHS 2012 and ASTM F1163.
- d) Judges engaged are to be RHAA approved, and listed on the current judges listing on the RHAA web page.
- e) Show Patterns will be supplied by the Judge.
- f) At ANY SHOW that runs an Approved RHAA program, an owner and / or exhibitor agrees that the Association or show committee and their agents or representatives can photograph, video or tape any portion thereof the show, and use their likeness and that of the exhibited horses for training, promotional or other legitimate purpose without necessity of remuneration. Parental permission must be sought for use of Youth photos.
- g) To compete in an RHAA-approved class, a horse must be entered in the class with show management prior to the start of the class.
- h) The exhibitor must accurately complete entries and assumes responsibility for any errors.
- i) A horse entered in the wrong class may be transferred to its correct class after the judging program has been printed at the show managers discretion.
- j) When exhibitor equipment failure causes a delay or a run to be discontinued, the Judge will disqualify the entry.
- k) Equipment or accessories that are considered unsafe or unfair, the Judge has the authority to require the removal or alteration of any piece of equipment or accessory which is unsafe, or in his/her opinion would tend to give a horse/rider an unfair advantage or which he/she believes to be inhumane.
- l) In all ridden classes' horses are to be ridden astride.
- m) Excessively loud or disruptive coaching or instructing from the sidelines during competition is not permitted and may result in a DQ.

- n) Show organisers must consider stallions in conformation classes. It is mandatory that stallions be placed either first or last in the lineup, with geldings placed where possible in front or behind, OR place stallions in a separate line up within the class.

5.2 OTHER SHOW RULES & ETIQUETTE

- a) Only paid & current financial members are permitted to handle or be mounted on a horse at any event. Only horses entered in a minimum of one class are permitted on the grounds. Excluding cattle herd help horses.
- b) Once a class is completed, you may be asked to line up in the arena for presentation for placings. You must be mounted on a horse you showed in the class, in correct attire and line up in an orderly fashion (straight line). If a competitor has entered on multiple horses, another member of the RHAA in suitable attire, may ride the horse in for presentation. In the Ranch on the Rail class, you will remain to be Judged, until ribbon is placed around horses' neck.
- c) The Committee reserves the right to remove any problem horse or rider from an arena and/or grounds if necessary.
- d) No exhibitor, parent of an exhibitor, or spectator may visit or socialise with a Judge on the day prior to, or the day of a show.
- e) No exhibitor, parent of an exhibitor, or spectator may request information from a Judge, or discuss any exhibit at the show during the event or within seven (7) days immediately following the show.
- f) Any queries regarding patterns, rules, concerns, or disputes regarding judging must be directed through the appropriate show official, including the scribe, show manager, ring steward, gate steward, or other appointed show officials. Exhibitors must not approach the Judge directly in any circumstance.
- g) Show management reserve the right to change the order of classes before or during the show. It is the responsibility of the exhibitor to be aware of any changes which will be posted at the Show Secretary's office and/or announced.
- h) Every endeavour will be made to give one hours' notice of any changes to the running order of events.
- i) No training equipment is allowed in the marshalling area or the performance arena one (1) hour prior to the commencement of the show and one (1) hour after the cessation of the show, on each day of the show.

- j) No lunging or exercising of horses is permitted in any arena while horses are being ridden.
- k) No change of handler is allowed without advising the show office at least one hour prior to the event taking place.
- l) Show management may exclude horses from competition should there be any unnecessary delay on the part of the exhibitor in bringing the horse into the competition arena. Failure to report on final call will result in disqualification from the class.
- m) Protests must be made in writing to the show secretary and be lodged within 1 hour of the completion of the disputed event. A cash fee of \$50 must accompany any protest.
- n) A dispute committee shall consist of the Show Manager, one show committee member and one competitor as selected by committee.
- o) No alcohol is allowed in or can be consumed in the marshalling areas, working arenas or show pen/contest areas at any time.
- p) Only show officials will be allowed in the competition arena during the judging.
- q) The Show Manager or such person he/she appoints shall have sole discretion to eject any exhibitor from the said area for inhumane treatment and/or training of any horse or failure to observe the Rules and Regulations of the competition and the Rules and Regulations of the RHAA
- r) All horses must be serviceably sound, the Judge and or Show Manager have the right to exclude any horse seen to be lame or injured.
- s) Neither the Ranch Horse Association of Australia, nor the sponsors or show organisers will be liable for any damage or loss that may occur to any person or animal.

5.2.2 UNREGISTERED HORSES

All *unregistered* horses must provide a proof of age certificate supplied by a Veterinarian to enter Prospect, Youth, Amateur or All Aged classes.

5.2.3 MARSHALLING AREA CONDUCT & ATTIRE

For competitors in the marshalling areas and show arena, whilst show is in progress. Refer to Index (Attire).

- a) For handlers in the marshalling area, whilst show is in progress, is a minimum of cap/hat, long Western style pants/jodhpurs, safe enclosed footwear and a shirt with sleeves
- b) For any person who has cause to enter the show arena to help set up trails etc. is a minimum of cap/hat, long Western style pants/jodhpurs, safe enclosed footwear and a shirt with sleeves.
- c) For any person using the arena or marshalling area when the show is not in progress, but the show has not finished, is a minimum of long Western style pants/jodhpurs, safe enclosed footwear, and a shirt with sleeves.

5.2.4 WARM UP PEN RULES

For the safety of our exhibitors, RHAA has established the following Warm Up area protocol:

In warm up areas, no cell phones, ear buds or headphones are allowed. For the safety of riders, fencing (running/stopping) should only be during designated times or when few riders are in the arena. Riders should practice spins in the middle of circles only. Beginning 2 hours before the show starts and during competition, only riders entered in competition are allowed horseback in warm up areas, no bareback riding and no riding double during that time frame.

One Circle Warm-Up Arena Etiquette



Large Arena Warm-Up Etiquette

- a) Always go with the flow of traffic. If the arena is large enough for two sets of circles, follow the diagram with a set of circles going each direction.
- b) NEVER stop your horse in traffic, and ALWAYS look behind you before you stop or slow down.
- c) Always look where you are going and watch out for other riders.
- d) Don't tie horses in the warmup arena.
- e) No cell phones, headphones, or ear buds in arenas.

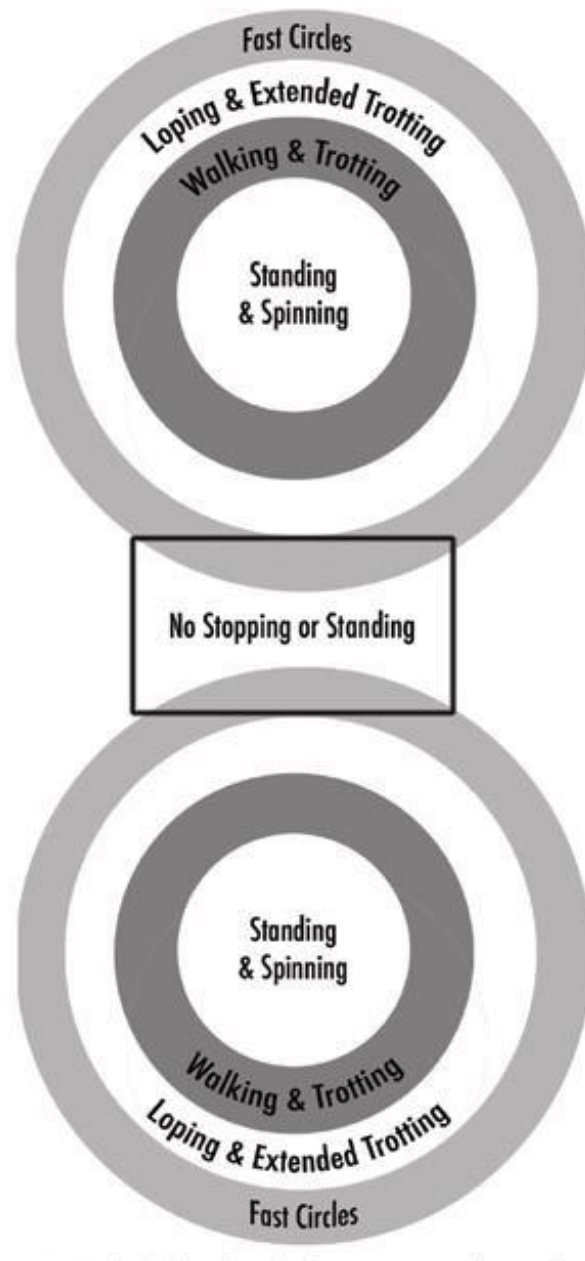

5.2.5 COMPETITOR CODE OF CONDUCT

- a) Competitors/participants of any event run by the RANCH HORSE ASSOCIATION OF AUSTRALIA have a responsibility to ensure the welfare of their horses and treat them humanely with dignity, respect, and compassion.
- b) Competitors/participants are to conduct themselves in a professional manner and act with integrity in all dealing with the Association and other competitors and agree to uphold the rules and regulations of the RANCH HORSE ASSOCIATION OF AUSTRALIA at all times.
- c) Competitors/participants are to demonstrate good sportsmanship at all times. Poor behaviour in the form of aggression, bad language or abuse of other competitors will not be tolerated. Persons involved in such behaviour may be excluded from the show and may be reported to the relevant breed association or society.
- d) Any exhibitor or rider who refuses to obey the request of the Judge, Show Manager or any Show Official, will be automatically excluded from further competition at the show and forfeits all previous winnings together with all entry fees and other charges.
- e) All competitors are to treat others with respect, always place the safety and welfare of children above other considerations, be responsible and accountable for their behaviour, follow the guidelines outlined in 'complaint handling policy' if they wish to make a complaint or report a concern about possible child abuse, discrimination, harassment, or other inappropriate behaviours.
- f) Committees are volunteers. Abuse or disrespect to any committee or show organiser will not be tolerated and incidents will be referred to the executive committee for discussion, and/or suspension or expulsion of a member.

5.2.6 RIDERS REPRESENTATIVE:

The show committee must appoint a Riders Representative before the contest starts or hold a meeting before each contest starts for the purposes of electing a representative of the contestants or a liaison (provided that person is a member of good standing of the RHAA) to work between contestants and show management. Riders' representative must be announced prior to commencement of the show. It is the responsibility of the host club to forward the riders representative report to the RHAA accompanying show results.

In the event the representative has to leave the show for any reason, he shall appoint a representative in his place for the duration of the show.

- a) Any representative elected or appointed must be a contestant.
- b) He must represent all contestants with the show management and be the sole liaison with the said management.
- c) He must report if he observes any horse being abused or if there are actions by any contestant detrimental to the best interest of the association such as the following: loud and profane language, drunkenness or being under the influence of intoxicants, use of devices not permitted by RHAA rules or any other infraction of standing rules.

A representative shall have no contact or communication with the Judge(s) beyond that permitted to any contestant.

The appointed representative shall complete the Riders Representative form at completion of the event and hand to show management for lodgment with the RHAA.

5.2.7 SHOW FINES AND PENALTIES.

- a) Probation Period will be from 30 to 90 days at the discretion of the Association. No privileges are denied, but any abuse during the probation period will be considered at the next highest level.
- b) Suspended Show Privileges will be from 3 months to 12 months at the discretion of the Association. All rights and privileges associated with Association sanctioned events and the Association Award System and Annual High Point Awards are denied during the period of suspension and presence on grounds of Association sanctioned events is prohibited.
- c) Fines imposed will be between \$100 to \$8,000 at the discretion of the Association. The quantum of any fine will be set out in writing to the party involved and 60 days will be given to pay the fine.
- d) Expulsion of a member is to be directed to the RHAA Disciplinary Officer in accordance with the RHAA Constitution.

5.2.8 RESPONSIBILITY

An individual is responsible for a horse's condition if:

- a) they designate themselves on the entry form as the exhibitor or authorises another to designate him/her as the exhibitor on the entry form.
- b) they sign the entry form on behalf of themselves or another or causes an agent or representative to sign it.
- c) they physically participate in the class by riding or showing the horse.

- d) they are the actual trainer, having presented or caused to be presented the horse at the grounds for exhibition.
- e) both the exhibitor, designated on the entry form, and the person having actual possession of the horse, while physically participating in the event, are conclusively deemed to be authorised by the owner to execute all documents necessary, or convenient, to allow the horse's participation in an event approved by the Association, including documents pertaining to drug testing.

An individual is prevented from performing their duties, including absolute responsibility for the condition of the horse/s, or is absent from the show, they must immediately notify the show secretary, at the same time appoint a substitute, and such substitute must place their name on the entry form or the exhibitor represents the owner regarding their horse(s) entered in an approved show.

5.2.9 LAMENESS

The Judge will examine all horses exhibited in any class for lameness. This is essential regardless of whether the competition indicates it is necessary.

Obvious lameness will be cause for disqualification & is considered evident as.

- a) consistently observable at a trot under all circumstances
- b) noticeable nodding, hitching or shortened stride.
- c) minimal weight-bearing in motion and/or at rest and inability to move.

5.2.10 PROHIBITED CONDUCT

Prohibited conduct but not limited to: No person on the grounds, including but not limited to barns, stall, practice areas or show arena, can treat a horse in a manner that includes:

- continuous and/or relentless pressure from the bit, legs, or spurs.
- placing an object, other than a legal bit, in a horse's mouth to cause undue discomfort or distress.
- placing a legal bit in a horse's mouth in an abnormal manner.
- leaving a bit in a horse's mouth for extended periods of time to cause undue discomfort or
- distress, broken skin and/or bleeding.
- tying a horse's head up (above the withers), back, or around in a manner as to cause undue discomfort or distress. the horse must be able to hold its head comfortably in a "normal" position.
- tying a horse in a stall without access to food or water for an extended period.

- use of excessive training techniques such as striking a horse's legs.
- excessive spurring or whipping.
- excessive spinning (defined as more than eight (8) consecutive turns in either direction).
- continuing to work or exhibit a horse which appears to be sullen, lethargic, emaciated, dehydrated, depressed, drawn or overly tired.
- breaking the skin and causing bleeding from the spur, bit, or any other equipment.
- riding or training in such a way that the horse is subject to periods of mental or physical distress.
- exhibiting a horse that has an open wound and/or shows traces of blood.
- using prohibited equipment on the horse at Association approved events.

Prohibited Any form of conduct that inhibits competition at Association approved events.

- Padding classes, by entering a horse(s) to fill a class to increase show points.
- Discouraging a potential competitor from entering a class.
- Any competitor inside the arena, assisting another competitor, may be disqualified. Exception: EWD, Youth Lead Line and Youth Walk & trot classes.
- Attempting to reduce competition or assisting in reducing competition by a member.
- Attempting to reduce competition by a non-member of the Association.
- Engaging in unsportsmanlike conduct including, but not limited to, inappropriate language.
- Carrying or consuming alcohol in the marshalling areas, working arenas or show pen/contest areas.
- Directing abusive or threatening conduct or language toward Association representatives.
- Entering any registered horse in any sanctioned event by a name other than that by which the horse is registered.

5.3 SUBSTANCES

Nutraceuticals or Herbal Therapies. The onus is on the Owner/Trainer/Handler/Exhibitor, who decides to administer these types of products to a horse, to ensure that they are free of any prohibited substance.

5.3.1 SURGICAL PROCEDURES

A horse cannot compete if it has had any surgical procedure which could affect the horse's performance. Exception: for those surgical procedures performed by a duly licensed veterinarian for the sole purpose of protecting the health of the horse. If requested, a Veterinary Certificate detailing the surgery will be required. Artificial appliances are not permitted for use in approved classes. The following are not prohibited:

- a) conventional pads
- b) therapeutic shoes
- c) Pacemakers or prosthetic eyes, if the owner obtains written permission from the Association and the resulting authorisation is noted on the horse's entries.
- d) Prohibited Drugs and Foreign Substances

5.3.2 PROHIBITED SUBSTANCES

A horse that has had any prohibited foreign substance or drugs administered internally or externally cannot compete.

- a) A patch of any type, medicinal or otherwise cannot be on a horse when that horse is being exhibited.
- b) A horse that is injured or taken ill once it has arrived at the official show venue, or whilst on the ground during the event, may compete after that horse has been treated by a Veterinarian at that show. The attending Veterinarian must sign a certificate which states:
 - i. what the horse is suffering from
 - ii. what treatment, including any substances that have been administered internally or externally, and that the horse is sound enough to compete at that show.
- c) The certificate must be given to the Show Secretary and or Show Manager prior to the horse competing.
- d) A horse cannot be injected at a show unless the Veterinarian, which attended the horse at the show, has otherwise instructed. A Vet Certificate showing the treatment required must be obtained.

5.3.3 ACCEPTABLE FOREIGN SUBSTANCES

The following substances are acceptable:

- Antiprotozoals
- Anti-ulcer medication
- Insect repellent
- Anthelmintics
- Rehydration fluids
- B vitamins (orally)
- Regumate/Altrenogest (mares only)
- Topical ointments not containing Corticosteroids, irritant, or painkillers.
- Preventative joint restorative therapies and general "over the counter" feed store supplements

Every exhibitor will, upon request of show management or the Association representative, permit a specimen of saliva, urine, blood, or any other substance to be taken for testing. Refusal to comply with such a request will constitute grounds for immediate disqualification of the horse from further participation at the event. If the laboratory report on the chemical analysis of saliva, urine, blood, or other sample taken from the horse indicates the presence of a foreign substance, prohibited drug or medication, this will be taken as prima facie evidence such substance has been administered to the horse.

Penalties and Restrictions. Any person, member, or non-member, found in violation of these rules will be disciplined, suspended, fined, denied Association privileges, disqualified, expelled from the grounds, and/or expelled from the Association. If, upon examination by Association or show representatives, after Association authorisation, a horse's physiological functioning is found to be outside normal limits, the horse will automatically be reported to the Association. Upon written notification by the Association, the horse's participation privileges in Association approved events will be suspended pending a hearing to determine whether the horse's physiological functioning remains abnormal, with the burden of persuasion on the owner to prove normal physiological functioning. Participation privileges of the horse will remain suspended until any hearing.

SECTION 6 – SHOW MANAGEMENT

6.1 RHAA SHOW APPROVAL

- a) No show of any kind will be approved on the dates of the Associations Annual General Meeting or the RHAA National Show.
- b) No RHAA show can be held within 500 kilometres, or within SEVEN (7) days either side of an RHAA State Show.
- c) No show approval will be given for any identity, on the same day as an already approved show or program, within 150km normal road distance from venue to venue, unless written permission is given by the Affiliate who has that date approved.
- d) When more than two shows are approved, a third show within a 300-kilometre radius will require written approval from the approved associations/clubs.
- e) Shows or programs, which have been granted approval in the following point's year, are subject to any rules that become effective from 1 August of that year.
- f) Results must be provided to the association clearly displaying RHAA member & Horse numbers for points to be tallied, within 30 days of the event. (Member & Horse register available for download from the RHAA website)
- g) Affiliates may apply for approval, and they must:
 - i. apply 21 clear days prior to the show.
 - ii. lodge the name of the Judge with the Association 21 days before the first day of the show.
- h) No approval will be considered until all paperwork, as requested by the Association, has been lodged, is complete, and correct.
- i) All approved shows and programs, depending on the type of program must be officiated by an AQHA VR or RHAA Judge
- j) If approval is sought to run Equestrian with Disabilities recognised classes, then the Show Committee assumes the responsibility for safety of all competitors.
- k) Show or program approval is a privilege, not a right, granted or rejected at the RHAA's discretion.
- l) according to continuous evaluation of the applicant including, but not limited to,
 - i. competence of show committee.

- ii. enforcement of RHAA Rules and Regulations.
- iii. quality of event.
- iv. service to RHAA members.
- m) Approval does not carry from year to year but must be obtained for each individual event and the RHAA reserves the right to approve only the number of shows or programs per calendar year as it deems appropriate for any Affiliate/Organisation.
- n) Changes cannot be made to an approved program that affects the approval of such program. Any changes to a program, must be notified in writing to the RHAA prior to the show, or recognition of EOY points may be rescinded.
- o) If the application for approval is satisfactory, the RHAA will issue a statement of approval. If approval is not granted, then the Association, in writing, will stipulate the reasons why.

If any RHAA Affiliate, and other Associations seeking show program approval, do not conform to the rules and regulations of the Association the following will apply:

- a) 1st Offence Warning
- b) 2nd Offence \$100 up to \$1,000 fine
- c) 3rd Offence No show approvals for three to six months

Fines: The quantum of any fine will be set out in writing to the party involved and 60 days will be given to pay the fine.

The RHAA does not assume or accept duty or responsibility for safety at any sanctioned event regarding participants or any other third parties, or for the horses or other property thereof.

As an express condition of privilege to participate at an RHAA approved show or sanctioned event, each horse owner, exhibitor, trainer and participant assumes the risks of participation and releases and discharges the RHAA, its officers, directors, representatives and employees, from any and all liability, whenever or however arising, as to personal injury, property damage occurring as a result of participation in a class/event conducted by the RHAA or RHAA Affiliate.

Show Committee is responsible for the.

- a) condition of event premises.
- b) conduct and competence of show staff and other representatives
- c) implementation of show activities and classes, and
- d) all other aspects of the event.

For RHAA Affiliates, any class that is not specifically mentioned in the RHAA Rule Book that aims to promote the ranch horse, and is in line with the RHAA Mission Statement, and has received RHAA show approval, may be run at an RHAA show. These class(es) will be **non-point scoring classes**.

Approval is a privilege, not a right, granted or rejected at RHAA's discretion on and according to continuous evaluation of the applicant, including, but not limited to competence of show management, enforcement of RHAA rules, quality of show, and service to RHAA members.

Final program must be submitted to the Secretary no later than 21 days prior to show date for approval.

EOY High Points will be collated upon submission by the Group/Club/Affiliate Secretary within 30 days of the show to the RHAA Points convenor or the following fines will apply:

- a) results received after 30 days \$200 fine.
- b) after 60 days \$400 fine.

No further show approvals will be granted until fines are paid in full.

No event is sanctioned by the Association unless the Association has been notified in writing prior to the event taking place. Until such time as a Show Approval is forthcoming from the Association, the event is not sanctioned by the Association, and a show program is not permitted to be advertised (including approval pending) or entries taken.

An Event Planning Checklist must be completed before commencement of any event and sent to the Association within fourteen (14) days of the completion of the event. This pertains to any event run by an RHAA Affiliate, under RHAA insurance.

The following rules apply to all Associations & RHAA Affiliates when running a sanctioned show;

- a) The rules in this Rule Book must be adhered to at all RHAA Affiliate events, including shows, and for organisations that been granted Program approval.
- b) The rules pertaining to Amateurs/Select Amateurs and Youth must be adhered to in all equine competitions.
- c) All horses present at an RHAA Affiliate show must be entered in the show. Excluding cattle event help horses.
- d) Only financial RHAA members will be eligible to receive points towards RHAA end of year high point and lifetime awards.

- e) A person expelled or suspended or not in good standing with the Association cannot exhibit or act as a handler/strapper at any RHAA approved event.
- f) Points will not be awarded to any horse exhibited or handled by a person so expelled, suspended or not in good standing with the Association.
- g) Persons as described above are prohibited from entering the official marshalling areas and show arena at any time for the duration of any event that has RHAA approval.
- h) Show Management may request a copy or sighting of: Horse Registration Certificate, aged veterinarian certificate and/or RHAA rider permits with entries.
- i) Show Committee will issue exhibitors separate entry numbers for each horse entered. Failure to wear a competitor number, or to display the correct number in a visible manner, will result in disqualification.
- j) It is mandatory that all patterns and courses be posted at least one (1) hour prior to the class commencing, however a minimum of two weeks is desirable.

6.1.2 INCIDENTS AT SHOWS

- a) Will be investigated by the Show Manager.
- b) The Show Manager, informed of the incident, will speak to the alleged offender and inform him/her, that a report will be filed with the Association re the alleged incident.
- c) If the Show Manager cites an alleged incident, they must act as per this rule.
- d) If an exhibitor, owner, and/or his/her representative acting on behalf of the exhibitor, is found to have engaged in:
 - i. unsportsmanlike conduct
 - ii. inhumane treatment of a horse, or
 - iii. a breach of any rule in this Rule Book, then they will be reported to the Association.
 - iv. Any incident reported to the Association, will be sent to an Investigative Committee to determine whether the alleged incident is founded and if further action is required.

The Association can give a warning, show fine and/or suspend the showing rights of the exhibitor, owner, and/or his/her representative acting on behalf of the exhibitor/owner, to participate in future approved shows for such period as the Association deems appropriate.

If an adverse decision is reached by the Investigative Committee, then the person in question has the right to appeal to the Executive Committee within 14 days of receiving the notification from the Investigative Committee of their decision.

6.1.3 HUMANE TREATMENT

The Association will not tolerate inhumane treatment of a horse or any other animal used in competition.

- a) No member or non-member will treat any horse or animal in a cruel or inhumane manner.
- b) Inhumane treatment includes but is not limited to all relevant animal welfare legislation and rules of the National Authorities controlling the applicable sport.
- c) In any equestrian sporting event, the welfare of the horse is always the primary consideration.
- d) No horse should be ridden or trained in such a way that it is subject to extended periods of mental or physical distress.
- e) Association members must comply with all relevant animal welfare legislation and rules. This applies to all horses exhibited at events sanctioned by the RHAA, RHAA Affiliates and at any event that has been given Association program approval.

The Association encourages all members to follow best animal welfare practice in all their dealings with horses.

6.1.4 RHAA DISCLAIMER OF RESPONSIBILITY FOR SAFETY

RHAA does not assume responsibility for safety of participants at the shows or other events, it sanctions and responsibility for participant safety remains solely with show management.

- a) Show management applies for RHAA approval on a voluntary basis, agreeing to conduct the show according to RHAA rules, which are designed to promote fair competition.
- b) Assumption of responsibility for safety by show management is required by RHAA as an express condition to grant the designation "RHAA-approved show." RHAA's limited objective is to require, by rule enforcement, a "level playing field" of competition in order that performance of exhibitor and horse can be Judged uniformly by competent Judges.
- c) and horses perform or are exhibited free of prohibited substances that could affect their performance. Safety is a concern of everyone, but

RHAA does not assume responsibility for it. RHAA's limited purpose for sanctioning a show is to promote fair competition.

- d) All Approved Shows and programs must use an entry form which contains information in regard to awarding of RHAA points, membership requirements, entry fees, stable & camping fees, and levies.
- e) It is the duty of a competitor to report to the Association within ten (10) days, any infraction of Rules at approved and unapproved Shows.
- f) Where an infraction is proven, points for that class may, at the Association's discretion be disallowed.

6.1.5 DISCIPLINARY PROCEDURES

The RHAA Executive Committee is the forum within RHAA that, ultimately, hears evidence of alleged violations of rules and regulations by members and/or participants in RHAA-approved events.

- a) A member may be disciplined, suspended, fined, and/or expelled from RHAA, and any non-member participant may be denied any or all RHAA privileges.
- b) RHAA rules pertaining to prohibition of drugs, surgical alteration or any inhumane treatment of the horse provide for absolute responsibility for a horse's condition by an exhibitor, trainer, participant and/or the owner, thereby making the exhibitor, participant and/or the owner eligible for possible disciplinary action upon proof of the presence of such prohibited drug by laboratory analysis, existence of surgical alteration or any inhumane treatment of the horse.

6.1.6 ENHANCEMENT OF PENALTY

RHAA reserves the right to independently direct disciplinary action or sanction against individuals coming under its jurisdiction by participation in RHAA-approved shows. The RHAA Committee may enhance or initiate suspension, fine and/or otherwise penalise offenders of RHAA rules and regulations, and/or those of other jurisdictions; and include owners or lessees who have placed the care and custody of their horses to such offenders.

6.1.7 RESPONSIBILITY OF SHOW MANAGEMENT

Reining Surface

The arena surface for Reining at Approved Shows, or programs, must be SAFE, being lightly ploughed and harrowed, or a suitably soft surface (sand, loam, sawdust, tanbark etc). Hard surface, grass or uncovered trotting tracks etc. do not constitute safe reining arena surfaces.

Cattle event surface;

Recommended minimum arena size to be 24m - 30m x 45m - 60m. Surface must either be of sand or tilled to a depth of 5cm to 15cm.

Exhibition/competition is deemed to have commenced when the horse and/or rider/handler has entered the marshalling area or has come under the direct control of Show Manager (typically Marshall/Steward) prior to entering the arena.

Any person, owning or leasing the grounds on which a show is being held will be prohibited from using said ownership to influence the outcome of any show held on the property.

6.1.8 PAY FOR SERVICES

Any RHAA-approved show which fails to pay for services rendered by third parties in connection with the holding of the approved shows (i.e. Judges' fees, cattle charges, facilities, insurance or drug testing fees, etc.) or pay premium monies to exhibitors can be denied RHAA approval for present and future shows. The sponsoring organisation can be denied privileges of RHAA and suspended from membership.

Show management delinquent and/or habitual in submitting

(1) show approval requests, (2) results, (3) incomplete information or (4) failing to submit electronic results will be reviewed by the RHAA Show Grievance Committee.

An "RHAA-approved event" means an official class of competition or show with results that are accepted by RHAA in its records as official.

RHAA will issue a statement of official approval of the proposed show or notify the organization or individual making the application of reasons for not approving a show or special event.

Lack of approval of any certain class in a proposed show need not invalidate the recognition of the remainder of the show.

All approved classes must be open to any RHAA registered horse or financial member meeting age, ownership, and eligibility requirements.

Show management has the option of holding some classes the afternoon or evening before their approved show date(s) provided that afternoon or evening does not conflict with another existing approved event. For example, at a weekend show, the Saturday show may begin the preceding Friday afternoon, and the Sunday show may begin on Saturday.

6.2 MISCELLANEOUS SHOW RULES

- a) Shows with multiple Judges and arenas may make trail classes available to exhibitors in a random order and position. Working order for this class also may be random;
- b) Scores in go-rounds or eliminations will not be counted towards placings – only the scoring in the final will be accepted.
- c) Concurrent Classes – That two (2) classes of the same discipline can be run concurrently. Show Manager and the Judge will make this decision. The Judges results will determine the placings for both classes that ran concurrently.
- d) Suggested ribbon placings colours as follows;
 - i. 1st: Blue
 - ii. 2nd: Red
 - iii. 3rd: White
 - iv. 4th Yellow
 - v. 5th Green
 - vi. 6th Pink or Brown

6.3 NATIONAL & STATE SHOWS

RHAA Membership is mandatory for all competitors entered at RHAA State & National shows.

6.3.1 NATIONAL CHAMPIONSHIP SHOW:

The RHAA committee, will formulate the program, Rules and Regulations pertaining to the National Championship Show. The RHAA National Show is run by the RHAA committee and includes cattle events. Hi Points are offered to all divisions.

National Show entitles entrants to triple EOY Hi Points. No show will be approved to run on the dates of the National Show Australia wide.

6.3.2 STATE CHAMPIONSHIP SHOWS:

Application for State Championship shows must be lodged directly to the secretary at least 120 days prior. The name of Judge/s must be lodged with the secretary via email; secretary@rhaa.com.au sixty (60) days prior to first day of show.

- a) State Show Applications will be approved by the RHAA committee;
- b) Any Club with their own insurance or RHAA Affiliate, in that State, can apply to run that State's RHAA State Championships.
- c) Program must include a minimum of one cattle and three dry events.

- d) No approval can be given to conduct State Championships without a program of classes being submitted which displays the amount of entry fees and a copy of the Affiliates Rules and Regulations for that State Show including classes that qualify High Point Awards.
- e) At State Shows the Show Secretary and the Show Manager must be financial RHAA members.
- f) RHAA will provide a cash donation of \$500.00 plus GST if applicable, to each approved State Championship host.
- g) All State Championship shows will receive RHAA double points.

6.4 SHOW TEAM;

6.4.1 ATTIRE

All Officials who have cause to enter the Show arena, at an RHAA Approved Show or an organisation running an approved RHAA program, whilst that Show is in progress, will wear Western attire including Western hat, Western pants, long sleeve collared, shirt (half or full button or zipper) (Collar = band, stand-up, tuxedo etc.)

6.4.2 OFFICIALS

- a) All Approved Shows or Programs must have a Show Manager or Arena Director.
- b) At State or National Shows, the Show Manager, Arena Director, Gate Marshall, Ring Steward, Show Secretaries, Announcers, ribbon presenters cannot officiate at this show until they have finished exhibiting horses.
- c) A Ring Steward must be 16 years of age and over. All other Officials must be eighteen (18) years and over with, the exception of Ribbon presenter;.
- d) An approved Bit Gauge must be used by an official at Approved Shows and for approved programs.

6.4.3 SHOW SECRETARY

- a) Any reputable person may act in the capacity of Show Secretary who can furnish proof that they are capable through ability and experience and is familiar with Association Rules and Regulations.
- b) It is recommended that the Show Secretary be a financial member of the RHAA.
- c) The Show Secretary will have authority over preparing and mailing all entry blanks and catalogues.
- d) A Show Secretary can hold the position of Show Manager at the same show.

- e) The Show Secretary will be held responsible for:
 - i. any fees collected on behalf of the Association
 - ii. clarification of eligibility of all entries, which includes checking the points & horse registration
 - iii. the completion of all results that must be forwarded to the Association
 - iv. filing with the Association any incident reports from that show

6.4.4 SHOW MANAGER

- a) Any reputable person may act in the capacity of Show Manager who can furnish proof that they are capable through ability and experience. It is recommended that the Show Manager be a financial RHAA member.
- b) A Show Manager can hold the position also of Arena Director at the same show; or
- c) A Show Manager can hold the position of Show Secretary at the same show but cannot hold the three (3) positions being Show Manager, Arena Director, and Show Secretary at the same show.
- d) The Show Manager is the person in charge of the running of the show and cannot hold the position of Ring Steward at the same show.
- e) The Show Manager will have the authority to enforce all rules and regulations referring to the Show. They may excuse any horse or exhibitor from the Show prior to, or during the judging, after consultation with the Show Committee.
- f) Show Manager will always extend every effort to satisfy the comfort of all horses, exhibitors, spectators, and officials. They will be held responsible for maintenance of clean and orderly conditions throughout the show.
- g) Show Manager will receive written complaints from exhibitors, trainers, owners, and other RHAA members of incidents of cruel, abusive or inhumane treatment of horses on the grounds and/or unacceptable behaviour of persons on the grounds and will forward such complaints to the Association for possible disciplinary action under these Rules and Regulations pertaining to animal welfare and unacceptable behaviour.

6.4.5 GATE MARSHALL

- a) Any reputable person may act in the capacity of Gate Marshall who can furnish proof that they are capable through ability and experience.
- b) A Gate Marshall is responsible to the Show Manager to carry out duties regarding the Show arena under the guidance of either the Show

Manager or if no Show Manager, then responsible to the Show Committee.

6.4.6 SHOW PHOTOGRAPHER

- a) No Official show photographer can exhibit a horse at a show that they are officiating at;
- b) They must be appropriately attired, when in the show arena, being shirt with sleeves, Western style pants/jeans and closed in shoes.

6.4.7 RING STEWARD (SCRIBE)

A competent Ring Steward will be required to officiate at all RHAA Approved Shows and for any organisation that has been given program approval.

Any reputable person or persons may act in the capacity of Ring Steward who can furnish proof that they are capable through ability or experience and are familiar with RHAA Rules and Regulations.

- a) Cannot hold any other position at a State or National Show but can rotate between the Ring Steward/Gate Marshall positions at other Shows.
- b) Ineligible if a member of their family will exhibit or act as agents, representatives in any capacity, or handlers of a horse at a show at which he/she is stewarding.
- c) Will notify the Judge when all horses are present for each class.
- d) Will report the number of horses in each class on the official sheets provided;
- e) Must mark on the result sheets/cards the time that each class has been completed;
- f) Must have in their mind that they have been selected to help the Judge – not to advise the Judge. They will carefully refrain from discussing or seeming to discuss the horses or exhibitors with the Judge. The Ring Steward will make sure that it is not perceived that they are taking part in the outcome of the class;
- g) When not actively engaged in their duties, will place themselves in such a position so as not to interfere with the judging or the viewing of the exhibitors;
- h) Must not allow the exhibitors to crowd up in the arena and should always endeavour to keep the possibilities of an accident at a minimum;
- i) Is to act as a mediator between the Judge and the exhibitor. The Judge should request the Ring Steward to move and place horses as they

advise. When the arena is small and the class entries are large, the Ring Steward should survey the situation and take every precaution to keep the horses moving until the Judge is ready for them to be Judged.

6.4.8 JUDGE

A Judge has the authority to remove exhibitors from the arena

6.4.9 SHOW DISPUTES COMMITTEE

Show Manager, a Show Committee Member, and an exhibitor who does not have a conflict of interest, make up the Dispute Committee.

Two (2) members of the Disputes Committee must be RHAA financial members. Youth are not permitted as part of a disputes committee. The committee is to investigate the dispute or incident and determine the validity of the dispute or incident within one hour of the class. The committee must forward all incident reports to the RHAA. The committee does not have the power to enforce any penalties or disqualify the exhibitor or owner at the time of the incident. The Committee has the power to rule on clerical errors.

6.5 HIGH POINTS

6.5.1 SHOW HIGH POINTS AWARDS

- a) Show High Point Awards are encouraged at all shows to reward versatility – it is however at the discretion of show management to decide whether to award high points and which divisions to include. The only exception being RHAA State or National shows, where high point awards are compulsory for all divisions offered in the program.
- b) Amateur, Select, Masters, Green Youth, Intermediate Youth & Youth can nominate a maximum of two horses per division for points. If more than one horse is entered in any rider division, only the highest placed horse will be allocated points towards high point awards at any approved show when an individual rider places twice in one class.
- c) To be eligible for Show High Point the horse or rider must show in the conformation class and a minimum of one ridden class within the same division.
- d) There is no maximum number of classes a horse or rider may contend; however, a horse may only be entered into a maximum of three divisions per show.

- e) A horse or rider shall be awarded points based on their placings in all classes contended, with the number of points awarded dependent on the number of horses/riders contending the class as per the below table:
- f) A rider may nominate a maximum of two (2) horses that will count toward a rider Hi Point at any single show.

6.5.2 SHOW HI POINT SCORING TABLE:

# of Horses in Class	1 st	2 nd	3 rd	4 th	5 th	6 th
6 or more	6	5	4	3	2	1
5	5	4	3	2	1	
4	4	3	2	1		
3	3	2	1			
2	2	1				
1	1					

The horse/rider with the greatest number of points accumulated throughout the show per division shall be awarded High Point Champion. Reserve High Point Champion Awards may also be awarded at the discretion of the show management

In the case of a tie occurring, the tie will be broken by:

- Greatest number of first place ribbons
- Greatest number of second place ribbons
- Greatest number of third place ribbons, and so on

For multi-Judged shows the points from each Judge's placings shall be added together to determine the Overall High Point Champion for each division.

SECTION 7 – JUDGING

7.1 DIVISIONS

- a) **“A”**. Limited prior judging experience. MUST ATTEND AN AQHA/RHAA WORKSHOP and pass the theory, video, and/or live horse judging. Newly qualified “A” Judge’s performance will be monitored by RHAA Judges Subcommittee.
- b) **“AA”**. Accredited AQHA Versatility Ranch (VR) Judges, who have passed RHAA accreditation, plus recognised RHAA Judges who have Judged a minimum of five (5) shows.
- c) **“AAA”**. Existing AQHA/RHAA VR Judges experienced in judging cattle events. MUST ATTEND AND PASS AN AQHA/RHAA cattle events test.
- d) **“AAA*”** Existing AQHA/RHAA VR Judges experienced in judging cattle events with multiple tickets (ie: AmQHA, NRHA, ARCHA, NRCHA, etc)
- e) The RHAA will recognise Approved NCHA, ARCHA, NRCHA Judges who have passed the RHAA rule book exam as **“RESTRICTED Cattle only”** Judges;

All rules pertaining to Judging as contained in this Rule Book, and any supplementary rules, will be implemented by the Association.

Judges may be assessed on an annual basis to be added or deleted at the discretion of the RHAA judging sub-committee.

Designation as a RHAA Judge is a privilege, not a right, bestowed & ratified by the RHAA committee, according to procedures formulated by the Association, to individuals whose equine expertise and personal character merit the honour. An individual’s conduct as a member, exhibitor and Judge, and their ability must be exemplary. The Judging convenor has the right to contact any existing Judge regarding their Judging commitments and/or abilities.

All RHAA approved Judges must officiate at a minimum of one show per annum or attend an RHAA Judges seminar at a minimum of bi-annually.

No Affiliate, which has gained show approval from the RHAA, can use the same Judge for two (2) consecutive shows, unless extenuating circumstances present, in which case the organising committee may apply to the RHAA Executive committee for special dispensation.

After acceptance of a judging commitment, a Judge will endeavour, with all reasonable effort, to Judge the show, and will timely communicate to show management any inability to do so. If a Judge cannot fulfil their commitment, then it is the responsibility of that Judge, in liaison with the Organisation that has hired them, to find a replacement Judge.

Additionally, the Judge will immediately file with the Association, a written explanation of such inability to meet the commitment, specifying the date and way they communicated it to show management.

7.2 DEFINITIONS

- a) An Accredited Judge is defined as a person who has met all the criteria required to hold an accredited Judges' ticket as approved by the RHAA.
- b) An AmQHA Judge is defined as a person who resides in the USA, and who has passed all the criteria approved by the AmQHA Judges Committee and can officiate at all levels.
- c) An AQHA International Judge is defined as a person who does not reside in the USA, who has passed all the criteria approved by the AmQHA Judges Committee and can officiate at all levels of shows.

7.3 AGES AND MEMBERSHIP

- a) Applicants must be at least 21 years of age. The mandatory retirement age of an RHAA approved Judge is 75 years of age. If a Judge wishes to continue judging past the age of 75, they must complete and pass an online Applicants Judges Test, &/or attend an RHAA Judges seminar at a minimum of bi-annually.
- b) All RHAA Judges & Judging applicants must be financial RHAA members. Single, family or Associate Membership.

7.4 JUDGES CONDUCT

An individual's conduct as a Judge must be exemplary and is subject to continual Committee reviews. Definition of Exemplary conduct – That a Judge's conduct is of such a high standard, that it is an example for others to follow and thus worth imitating, therefore Judges must conduct themselves in a manner deemed by the Executive committee as appropriate.

- a) To make formal complaint against an RHAA Judge, such complaint must be in writing, signed by the complainant and contain the specific facts giving rise to the complaint, and be received by the Association via email to;

Judges@rhaa.com.au, within fourteen (14) days from the date of the occurrence.

- b) Judges will be provided details of the complaint, then given a 21 day right of reply.
- c) The RHAA Judging sub-committee will conduct a full investigation.
- d) If the alleged complaint is substantiated, then the individual's Judge's ticket may be suspended or removed.
- e) If a Judge is suspended from Association membership, the individual will automatically be removed from the list of Judges and there will be no provision for automatic reinstatement as an RHAA Judge.
- f) Judges having their qualifications withdrawn or downgraded, have one (1) month to fulfil existing commitments.
- g) Upon regaining eligibility for judging credentials, the individual will apply for reinstatement after the expiration date of one (1) year from the date of their disqualification under the current procedures for admission of new applicants.

7.5 THE EVENT

A Judge will:

- a) Upon arrival in the city where they are to officiate, contact an official of the show and advise that person of their presence and location.
- b) Not appear on the grounds where the show is being held more than one (1) hour before judging.
- c) Not visit the horse stall area, nor visit with owners, trainers, exhibitors, or owners' representatives, nor inspect or discuss any horse entered in the show before the judging.
- d) Not review the show catalogue until after the judging has been completed but will be furnished a schedule of classes by the show management prior to the judging.
- e) Be present to meet their responsibilities under Association rules and regulations and will be available to assist show management in meeting its responsibilities of rule compliance.
- f) At all times act in a professional manner

7.6 ATTIRE

Western attire, including Western hat, coat (except in extreme weather conditions), Western style pants/jeans, long sleeve, collared shirt (half or full button or zipper) (Collar = band, stand-up, tuxedo etc.) and Western boots are mandatory apparel for an individual to wear whilst judging an RHAA approved show or program.

7.7 PLACINGS

- a) Once a class has been Judged, it will not be rejudged, and once the Judge has marked their record and placings are made, there will be no changing of the Judge's record.
- b) A Judge can change their Judge's card/sheet if there is proper documentation and proof that a clerical error has occurred. Clerical errors must be corrected within a reasonable period, but not more than one (1) hour after the last class of the day.
- c) It is the responsibility of the Judge to ensure, prior to signing their card, that the number of entries, scores and placing's are correct.

7.8 CONFLICT

RHAA Judges are to be sensitive to any conflict of interest between the Association's objectives and their own personal business or pecuniary interest.

Each Judge is to refrain from using their official status to further one's own personal or financial purpose. When such conflict of interest arises, the Judge is expected to either withdraw the personal objective from the transaction in question or resign from the Association's Judges list, so that he or she may pursue the personal objective. Breach of this ethical rule will be subject to review by the Judges Committee under the Association rules. Certain specific areas of obvious conflict of interest for Judges are as follows:

- a) Neither the Judge nor members of their family will exhibit or act as agents, representatives in any capacity, or handlers of a horse at a show at which he/she is officiating.
- b) A horse cannot be shown under a Judge if that Judge has been the owner, trainer or agent in any capacity, or conditioner of that horse within the previous 30 days. Group lessons i.e. clinics, schools and seminars are exempt from the above rule. (Must include 8 or more participants)
- c) A horse cannot be shown under a Judge if that Judge or their immediate family have exhibited that horse in the previous 30 days.

- d) A Judge will not Judge a horse that is owned by anyone from whom he/she has received a salary, commission, or any kind of remuneration for selling or buying any horse for that individual. or, whether or not the horse is concerned in a transaction, has been in any employ or has represented such individual in any capacity for remuneration, within one (1) month from the date of the subject show.
- e) Any RHAA Judge involved in the management of a show cannot officiate as a Judge at that Show.
- f) A Judge cannot Judge a horse belonging to, or being exhibited by, any member of their immediate family. (Spouse, De facto partner, parents, child of the family, grandparents, brothers, sisters). If such a horse as specified is entered in a show, its entry fee will be refunded, and it is not to be exhibited.
- g) These specified areas of disqualifying conflict of interest are not exclusive, and Association Judges are ineligible to Judge another's horse in other situations not designated by the rule.
- h) If a Judge cannot exercise their objective influence, because of their connection with an owner, exhibitor, or anyone else connected with the horse, or, for that matter, if such connection would appear to others as possible bias, whether or not the Judge feels that they would be affected, a Judge must disqualify themselves.
- i) The Judge at any show may also be on any sifting or elimination committee necessary.
- j) After a Judge has accepted a judging assignment, exhibitors will not contact, by any means, nor attempt to contact, the Judge pertaining to their judging of any horse at that show
- k) No exhibitor will visit or socialise with a Judge the day prior to, or day of, the show.
- l) No exhibitor will request information from the Judge concerning any exhibit at a show at the time of the show or within the immediate seven (7) days following the show.

7.9 FEES

- a) Minimum pay for an AA, AAA Judge is expenses plus three hundred dollars (\$300.00) for a day of eight (8) hours or less and thirty dollars (\$30.00) per hour over eight (8) hours in one day.
- b) It is recommended that car related travel be charged at the published cents per kilometre rate on the Australian Taxation Office website.
- c) It is further recommended that the Judge work no more than ten (10) hours in one day. If the hours spent in judging are expected to run to an excessive length, the show management must consider hiring two (2) Judges.

7.10 AUTHORITY

A Judge may:

- a) Disqualify a competitor who has not fulfilled the requirements of a class as described by the Associations Rules and Regulations.
- b) Require the backing of the finalists only in a class where backing is required.

A Judge will:

- a) Order any person or horse from the competition for bad conduct of one or both or may disqualify any exhibitor for excessive abuse of a horse.
- b) Refuse entry into the arena or remove an entry from a class for improper attire and/or equipment.
- c) Eliminate any horse/exhibitor, as an entry, which they feel is in violation of the intent of the Association's conduct rules, or which they feel has not legitimately attempted to exhibit the horse to the best of the horse's ability.
- d) Penalise a horse for excessive or exaggerated switching or wringing of the tail.
- e) Not penalise a horse for the way it carries its tail nor for normal response with its tail to cues from its rider or when changing leads.

NB: If a Judge suspects that a horse's tail has been surgically or chemically altered or has had any item or appliance that restricts the movement or circulation of the tail, then the Judge must report this horse to the Association. Judges suspicion is not cause for the Judge to not place the horse.

- a) Not call exhibitors off the rail at any gait other than a walk in a rail class.
- b) Have the authority to require the removal or alteration of any piece of equipment, or any piece of apparel, which in their opinion is unsafe and would tend to give a horse an unfair advantage or which they believe to be inhumane.

- c) Disqualify a horse that is exhibited with an open wound and/or shows traces of blood.
- d) Disqualify a horse who has a bleeding mouth in any class.
- e) Disqualify a horse if the horse appears sullen, dull, lethargic, emaciated, drawn or overly tired.
- f) Have the authority to place a horse in whatever position in a class they think is justified by the merits of the horse. The Judge's decision is final.

In the case of multi-Judged shows. Judges may confer on lameness via the ring steward in a non-identifying manner. The procedure to be followed: the Judge shall inform the ring steward that they have a horse that they have deemed as lame that they wish to excuse, without identifying the horse to the other Judge. The steward shall approach the other Judge and ask if they have any horse in the class, they have deemed lame. In the case that the second Judge has identified a lame horse that they wish to have excused, that Judge shall give the exhibitor number to the steward, the steward shall return to the first Judge and ask for their exhibitor number and if both Judges deem the same horse to be lame that horse shall be excused from the arena.

Should only one Judge deem a horse to be lame that horse will be able to continue in the class and be Judged independently by both Judges.

Horses shall be brought to the walk and the horse that is to be excused shall be discreetly directed to the exit gate by the ring steward.

SECTION 8 – POLICIES

8.1 APPEALS

The RHAA is the governing body responsible for setting the rules and guidelines that determine rider eligibility for all divisions. These rules include factors such as age, experience, and any other requirements relevant to each class.

Riders may apply for extenuating circumstances if they believe a different division is more suitable. Applications must be submitted in writing to the RHAA Appeals committee and will determine whether the rider is eligible for the division. If it is determined that the rider/horse is no longer eligible they will be permitted to complete the season but must move to a division determined the following show season.

The Appeals Sub-Committee will review each submission fairly and independently, consider the circumstances and make a recommendation or determination based on RHAA rules and principles of procedural fairness.

Any dispute or complaint regarding a rider's division entry or eligibility must be submitted in writing by a current financial member to; appeals@rhaa.com.au and supported by documented evidence. Where these requirements are met, the respondent will be given the opportunity to respond in accordance with procedural fairness and natural justice prior to a full committee determination.

8.2 COMPLAINTS MANAGEMENT POLICY

The Ranch Horse Association of Australia (RHAA) is committed to managing complaints in a fair, transparent, and accountable manner, consistent with procedural fairness and applicable legislation.

8.2.1 LODGING A COMPLAINT

- a) All complaints must be submitted in writing to the RHAA Secretary via email; secretary@rhaa.com.au
- b) Anonymous complaints are **not** accepted unless involving child safety or serious risk.
- c) Complaints will be acknowledged within a reasonable timeframe.

8.2.2 ASSESSMENT & PROCEDURAL FAIRNESS

- a) All parties will be treated fairly and without bias.
- b) Both complainant and respondent will receive relevant details.
- c) Each party will have an opportunity to respond.

- d) Only factual, relevant evidence will be considered.
- e) Decisions will be impartial, consistent, and documented.

8.2.3 COMPLAINTS OUTSIDE RHAA JURISDICTION

- a) The RHAA will not manage trivial, vexatious, or interpersonal disputes unrelated to RHAA activities.
- b) Matters may be referred to external bodies such as state tribunals or police.

8.2.4 MANDATORY REPORTING & CRIMINAL CONDUCT

Any suspected criminal behaviour, including assault, child-related concerns, or unlawful conduct, will be reported to authorities without delay.

8.3 PRIVACY & PERSONAL INFORMATION MANAGEMENT POLICY

The RHAA is committed to protecting personal information in accordance with the Privacy Act 1988 (Cth) and the Australian Privacy Principles (APPs).

8.3.1 COLLECTION OF PERSONAL INFORMATION

The RHAA may collect personal information when members apply for membership, enter events, or participate in RHAA programs.

8.3.2 USE & DISCLOSURE OF PERSONAL INFORMATION

Personal information may be used for:

- a) Processing memberships and transactions
- b) Managing member accounts
- c) Communicating updates and RHAA activities
- d) Improving RHAA services
- e) Compliance with legal obligations
- f) Assisting law enforcement where legally required

Members may request limits on use or disclosure of their information by contacting the Secretary.

8.4 SOCIAL MEDIA & PUBLIC COMMUNICATION POLICY

All members, competitors, officials, volunteers, and participants must use social media responsibly and uphold the reputation of the RHAA and the Ranch Horse industry.

Acceptable Use; Members may share positive and factual experiences relating to RHAA activities.

Prohibited Conduct; Members must not:

- a) Harass, bully, defame, or abuse others
- b) Criticise Judges, officials, or decisions publicly
- c) Comment on active investigations or disciplinary matters
- d) Disclose confidential information
- e) Make statements damaging to RHAA's reputation

Consequences;

Breaches may result in:

- a) Formal warning
- b) A fine of \$500.00
- c) Referral to the Disciplinary Committee
- d) Suspension or cancellation of membership

8.5 ANIMAL WELFARE POLICY

(In accordance with Australian Commonwealth & State/Territory Animal Welfare Legislation)

The Ranch Horse Association of Australia (RHAA) is committed to upholding the highest standards of animal welfare at all sanctioned events. This policy is guided by:

- a) Australian Animal Welfare Standards and Guidelines
- b) State and Territory **Animal Welfare** and **Prevention of Cruelty to Animals Acts**
- c) The Association's duty of care to ensure all animals are handled ethically, safely, and humanely

This policy applies to:

- i All sanctioned RHAA events
- ii All affiliated club events
- iii Any organisation granted approval to run an RHAA-endorsed program

8.5.1 WELFARE OF HORSES IN COMPETITION

Event organisers and competitors must respect the physical and mental wellbeing of horses in accordance with the above legislation and guidelines.

To minimise welfare risks:

- a) No horse may be entered in more than three (3) divisions per show, including Youth divisions, or in any number of classes likely to cause undue physical strain, exhaustion, or mental distress.
- b) Horses must not participate if showing signs of illness, injury, undue fatigue, lameness, or distress.
- c) No horse is to be entered more than once in any class.
- d) Horses must be handled humanely at all times, with no tolerance for abusive, excessive, or coercive behaviour.

8.6 PENALTIES AND RESTRICTIONS

- a) Any person, member, or non-member, found in violation of these rules will be disciplined, suspended, fined, denied Association privileges, disqualified, expelled from the grounds, and/or expelled from the Association. If, upon examination by Association or show representatives, after Association authorisation, a horse's physiological functioning is found to be outside normal limits, the horse will automatically be reported to the Association.
- b) Upon written notification by the Association, the horse's participation privileges in Association approved events will be suspended pending a hearing to determine whether the horse's physiological functioning remains abnormal, with the burden of persuasion on the owner to prove normal physiological functioning.
- c) Participation privileges of the horse will remain suspended until any hearing. Any hearing under this Rule must be requested by the owner.

A conviction of an individual, under State or Federal Law, will constitute a presumed violation of these rules for an offence of cruelty to, or judicial confiscation of a horse.

8.6.2 AUTHORITY OF THE RIDER REPRESENTATIVE

The appointed Rider Representative has the authority to:

- a) **Intervene immediately** if a horse is being mistreated, mishandled, ridden excessively, or subjected to behaviour contrary to animal welfare laws
- b) **Stop or suspend** a competitor's run where the welfare of the horse is compromised

- c) Report any breaches to the Show Manager or Executive Committee for further action

Their authority extends to any conduct “*detrimental to the best interests of the horse,*” as required under relevant Animal Welfare Acts.

8.6.3 IMMEDIATE RESPONSE TO DEBILITATED OR DISTRESSED ANIMALS

If a horse becomes injured, overheated, distressed, or debilitated:

- a) The situation must be addressed **immediately**
- b) The run or class **must be halted**
- c) Veterinary care must be summoned if needed
- d) The animal must be removed to a safe, quiet location

Failure to act may constitute an offence under state and territory animal welfare legislation.

8.7 CATTLE WELFARE POLICY

(In accordance with Australian Animal Welfare Standards & Guidelines – Cattle & POCTA Legislation)

Cattle used in RHAA events must be managed in accordance with:

- a) Australian Animal Welfare Standards and Guidelines – Cattle (2021)
- b) Australian Animal Welfare Standards and Guidelines – Land Transport of Livestock (2022)
- c) Relevant state/territory Animal Welfare and Prevention of Cruelty to Animals Acts

Cattle must be handled calmly, humanely, and competently, with every effort made to minimise stress, fatigue, and injury.

8.7.1 SELECTION AND MANAGEMENT OF CATTLE

Organising committees must ensure:

- a) As far as practicable, cattle used in events are **uniform in size, type, breed, and temperament**
- b) Aggressive, excessively flighty, injured, or unsuitable animals are **removed (“culled”)** from the group prior to competition
- c) All animals are fit for purpose and free from conditions that compromise welfare
- d) Cattle must have **two sound eyes** (healed pink eye scarring is acceptable)

8.7.2 MANDATORY CARE REQUIREMENTS

The following measures are **compulsory** at all Sanctioned/Approved events:

8.7.3 FEED

- Hay must be provided to cattle held overnight in accordance with basic care standards.

8.7.4 HEAT MANAGEMENT

Shade must be provided for cattle when temperatures reach the mid-30°C range or when heat stress risk is elevated.

- Sprinklers are to be used **with caution**, as they may increase humidity and inadvertently worsen heat stress.

8.7.5 WATER

- Clean, fresh drinking water must be **continuously available** in holding areas.

8.7.6 HANDLING OF CATTLE

- a) The use of dogs to move cattle in holding yards is **strictly prohibited**.
- b) Cattle must only be handled by **competent stock handlers**, using calm, low-stress practices.
- c) The use of **electronic devices**, including electric prodders, is prohibited, except where permitted under state law for emergency safety and only by authorised personnel.

8.7.7 INJURED OR DISTRESSED ANIMALS

In the event that an animal is injured:

- a) A suitable livestock transport vehicle must be available for removal.
- b) A **protective screen** must be used to minimise public visibility and animal distress during removal.
- c) Event staff must ensure safe, prompt relocation for assessment or treatment.

8.7.8 SUSPENSION OF COMPETITION FOR WELFARE REASONS

If any animal (horse or cattle):

- a) Becomes injured
- b) Shows signs of heat stress
- c) Exhibits extreme fatigue or distress
- d) Is otherwise unfit to continue

The class or individual run **must be stopped immediately** and welfare procedures followed.

8.8 HEAT MANAGEMENT & EXTREME WEATHER POLICY

The RHAA is committed to safeguarding horses and participants during periods of high heat, following the Australian Horse Welfare and Wellbeing Toolkit.

8.8.1 ENVIRONMENTAL HEAT LOAD

High temperature, high humidity, and low wind reduce the effectiveness of sweating for cooling.

8.8.2 MEASURING THERMAL RISK (WBGT)

The Wet Bulb Globe Temperature (WBGT) is the most accurate measure of total heat load.

8.8.3 HEAT RISK LEVELS & ACTIONS

- a) WBGT > 33 EXTREME — Event must be delayed, postponed, or cancelled.
- b) WBGT 30–33 HIGH — Hold events only in cooler parts of the day. Modify classes and increase cooling measures.
- c) WBGT 28–30 MODERATE — Reduce workload, use shade, ensure cooling facilities.
- d) WBGT < 28 LOW — Normal operations with ongoing welfare monitoring.

8.8.4 GROUNDS & FACILITY REQUIREMENTS

- a) Provide shade and ventilation.
- b) Ensure wash bays and adequate water supply.
- c) Provide ice, scrapers, and cooling equipment.

WBGT	Temperature Relative Humidity **	Alert Level	Actions
<u>>33</u>	e.g. >32oC, 60% RH >35 oC, 40% RH	EXTREME	Very high risk. Event must be delayed, postponed or cancelled.
<u>30-33</u>	e.g. 30oC, 65% RH	HIGH Seek veterinary advice.	Competition should be held in the cooler part of the day – prior to 11am or after 4pm. Horses and riders involved in high intensity events will require aggressive cooling measures. Reduce competition stress, such as by modifying the course/competition. Ensure sufficient cooling equipment and facilities are available. PA announcements remind riders to rehydrate and cool their horses, and for people to seek shade and water.
<u>28-30</u>	29oC, 60%	MODERATE	Use shaded areas where possible. Avoid non-grassed riding surfaces. Reduce competition stress, such as by modifying the course/competition. Ensure sufficient cooling equipment and facilities are available. PA announcements remind riders to rehydrate and cool their horses, and for people to seek shade and water.
<u><28</u>	30oC, 45%	LOW	Practice good animal welfare and go ahead

8.8.5 MANAGING PARTICIPANTS

Strenuous work over 6 minutes is *high risk* in elevated WBGT.

8.8.6 SIGNS OF HEAT STRESS IN HORSES

- a) Elevated temperature
- b) Rapid breathing, poor recovery
- c) Dehydration indicators
- d) Distress or agitation
- e) Excessive or absent sweating

8.8.7 COOLING MANAGEMENT

- a) Wet and walk
- b) Use ice water when needed
- c) Allow unrestricted drinking
- d) Ensure horses are cooled before travel

SECTION 9 – SHOW PATTERNS

All patterns and pattern descriptions are adopted from the AmQHA Rule Book



Ranch Riding - Walk/Trot Pattern 1

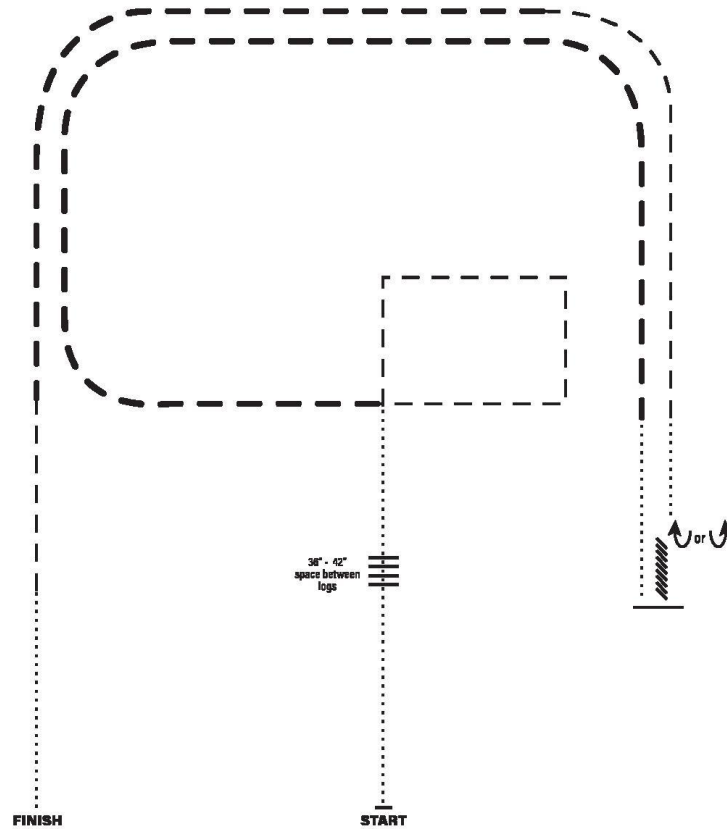

LEGEND	
.....	Walk
.....	Extended Walk
- - - -	Trot
- - - -	Extended Trot
————	Lope
————	Extended Lope
////	Back
↘	Lead Change

1. Walk over logs
2. Trot square at center
3. Extended trot at midline
4. Walk
5. Stop and back approximately 2 horse lengths
6. 180° (1/2) turn either direction
7. Walk
8. Trot
9. Extended trot
10. Collect to a trot
11. Walk

Note: The drawn description of this pattern is only intended for the general depiction of the pattern. Exhibitors should utilize the arena space to best exhibit their horses.

Ranch Riding - Walk/Trot Pattern 2

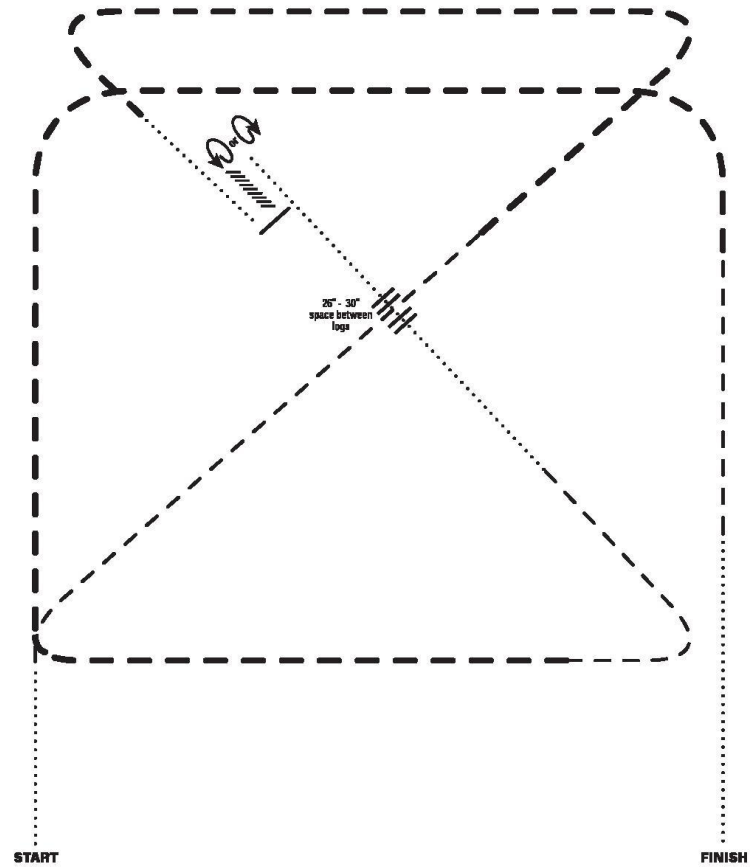

LEGEND	
.....	Walk
.....	Extended Walk
---	Trot
---	Extended Trot
---	Loge
---	Extended Loge
~~~~~	Back
W	Lead Change

1. Walk
2. Trot between logs
3. Extended trot
4. Walk, stop and back
5. Turn 360° either direction
6. Walk over logs
7. Trot
8. Extended trot
9. Collect to a trot
10. Walk

*Note: The drawn description of this pattern is only intended for the general depiction of the pattern. Exhibitors should utilize the arena space to best exhibit their horses.*

Ranch Riding - Walk/Trot Pattern 3

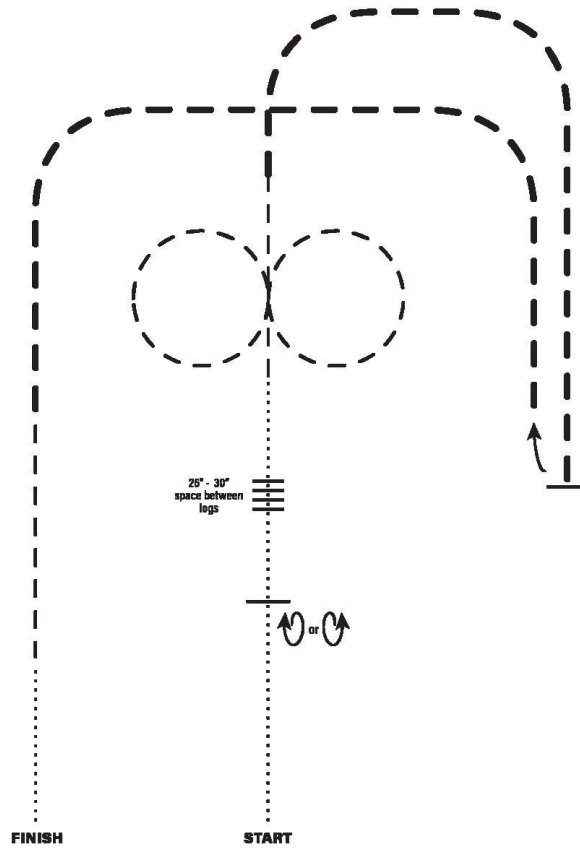

LEGEND	
.....	Walk
.....	Extended Walk
---	Trot
---	Extended Trot
---	Lope
---	Extended Lope
////	Back
↔	Lead Change

1. Walk
2. Stop, 360° turn either direction
3. Walk over logs
4. Trot a figure 8, either direction first
5. Extended trot, stop
6. 180° (1/2) turn right
7. Extended trot
8. Collect to a trot
9. Walk

*Note: The drawn description of this pattern is only intended for the general depiction of the pattern. Exhibitors should utilize the arena space to best exhibit their horses.*

Ranch Riding - Walk/Trot Pattern 4

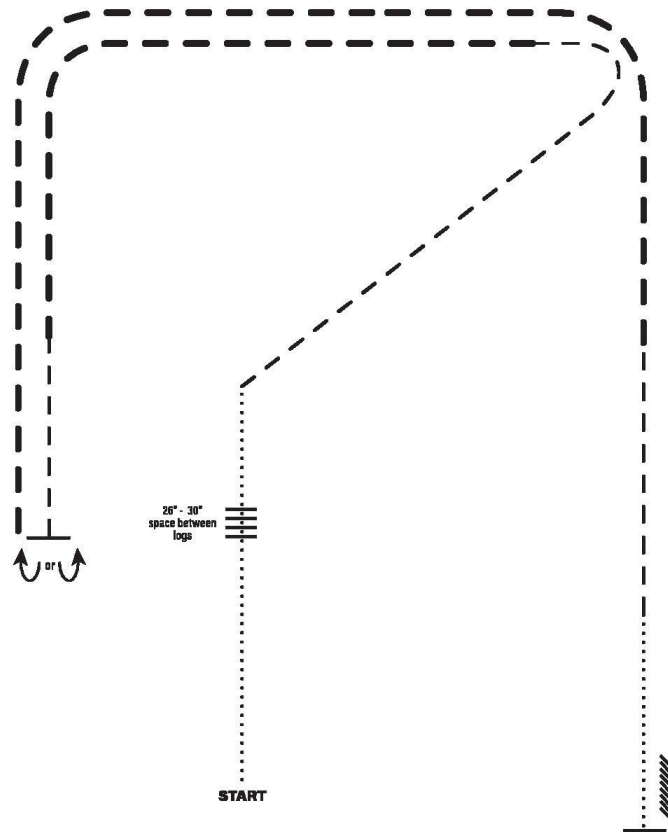

LEGEND	
.....	Walk
.....	Extended Walk
- - - -	Trot
- - - -	Extended Trot
— — —	Logs
— — —	Extended Logs
//////	Back
W	Lead Change

1. Walk over logs
2. Trot
3. Extended trot
4. Collect to a trot
5. Stop
6. 180° (1/2) turn either direction
7. Extended trot
8. Collect to a trot
9. Walk
10. Stop and back

*Note: The drawn description of this pattern is only intended for the general depiction of the pattern. Exhibitors should utilize the arena space to best exhibit their horses.*

Ranch Riding - Walk/Trot Pattern 5

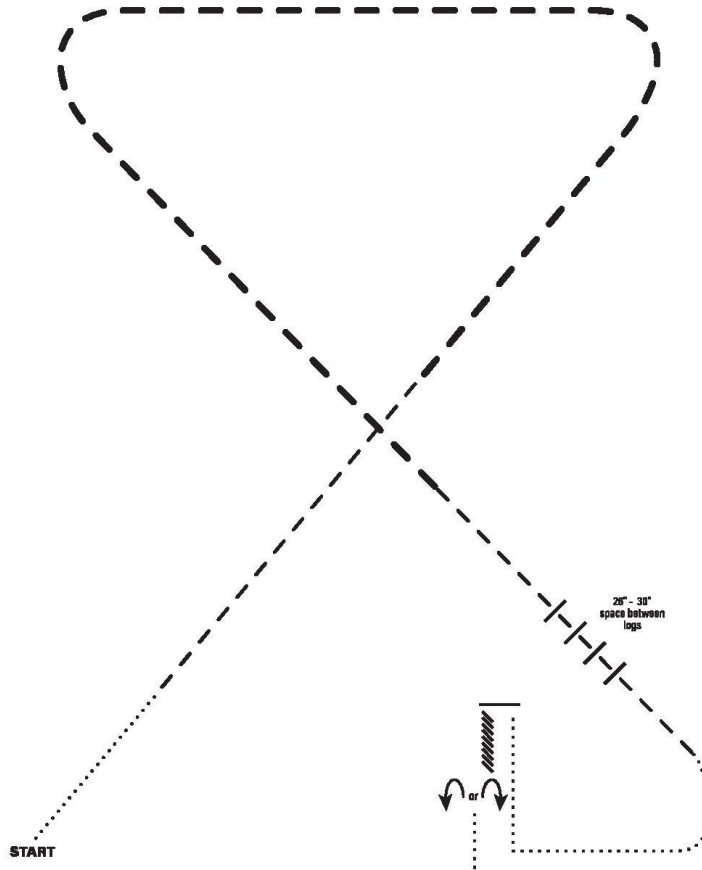

LEGEND	
.....	Walk
.....	Extended Walk
- - - -	Trot
- - - -	Extended Trot
————	Lope
————	Extended Lope
//////	Back
∩	Lead Change

1. Walk
2. Trot
3. Extended trot
4. Trot over logs
5. Walk
6. Stop
7. Back
8. 180° (1/2) turn either direction
9. Walk

*Note: The drawn description of this pattern is only intended for the general depiction of the pattern. Exhibitors should utilize the arena space to best exhibit their horses.*

# RANCH RIDING PATTERN 1

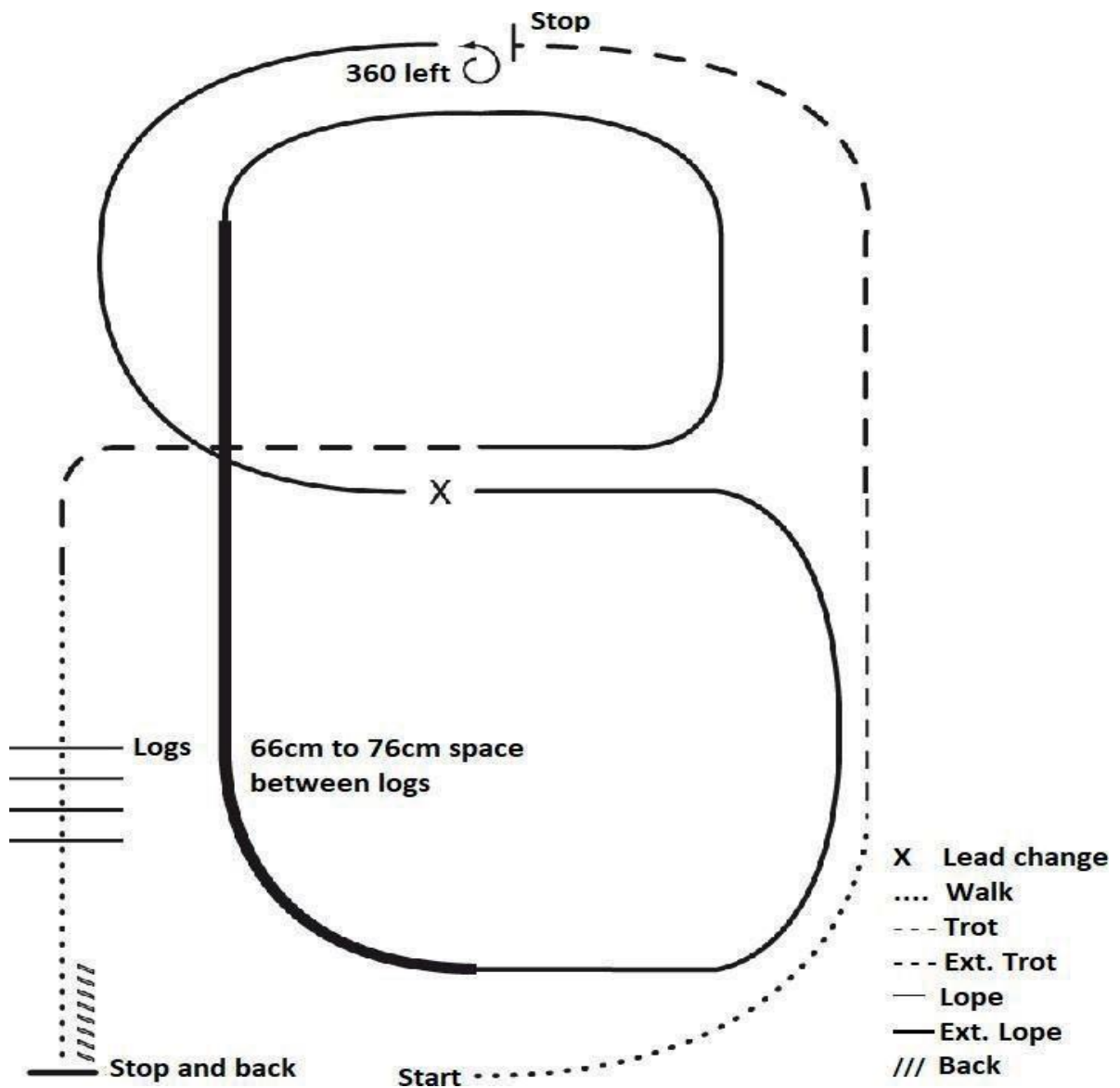

1. Walk
2. Trot
3. Extend the trot, at the top of arena, stop
4. 360° turn to the left
5. Left lead ½ circle, lope to centre
6. Change leads (simple or flying)
7. Right lead ½ circle
8. Extended lope up the long side of the arena (right lead)
9. Collect back to a lope around the top of the arena and back to centre
10. Break down to an extended trot
11. Walk over logs
12. Stop and Back

## RANCH RIDING PATTERN 2

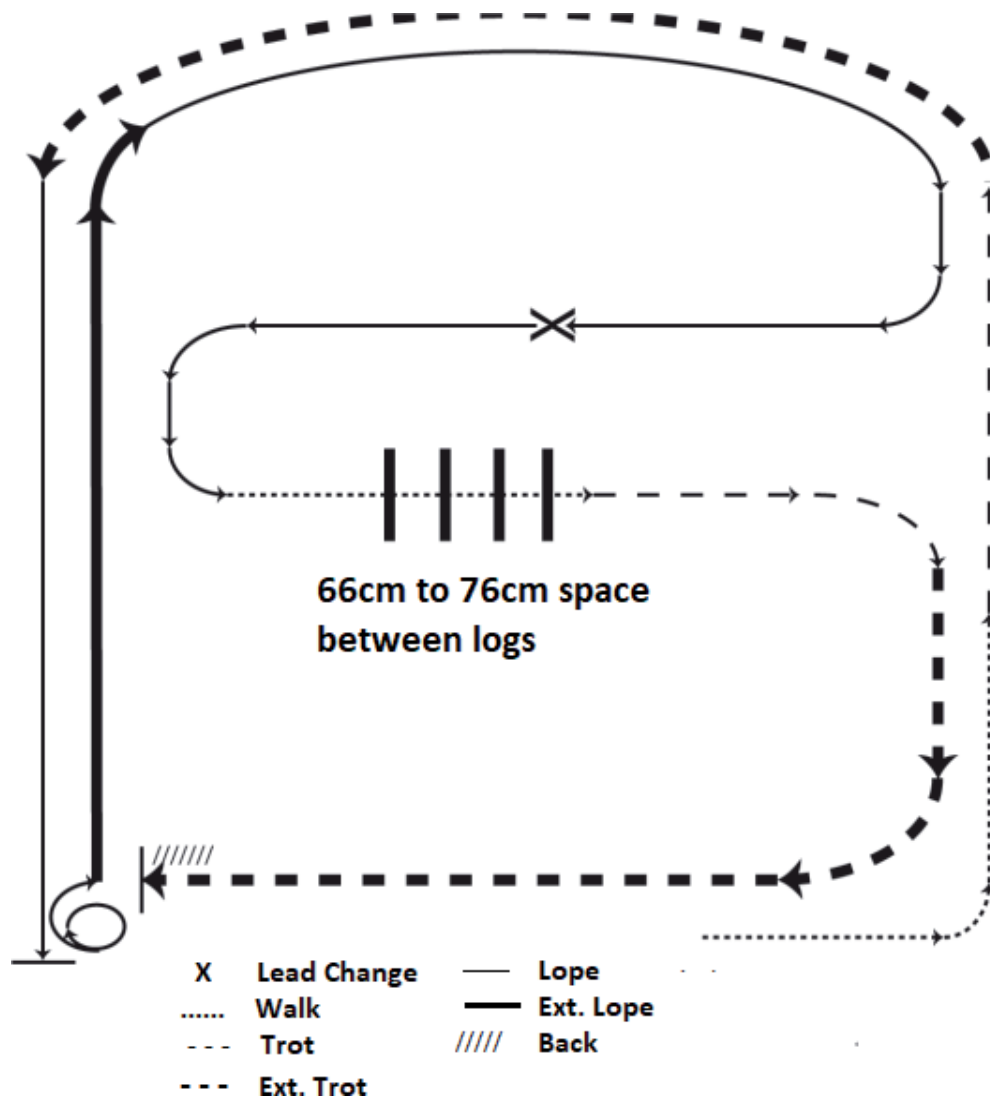

1. Walk
2. Trot
3. Extended Trot
4. Left lead lope
5. Stop. 1½ turn right
6. Extended lope
7. Collect to working lope, right lead
8. Change leads (simple or flying)
9. Walk
10. Walk over logs
11. Trot
12. Extended trot
13. Stop and back

## RANCH RIDING PATTERN 3

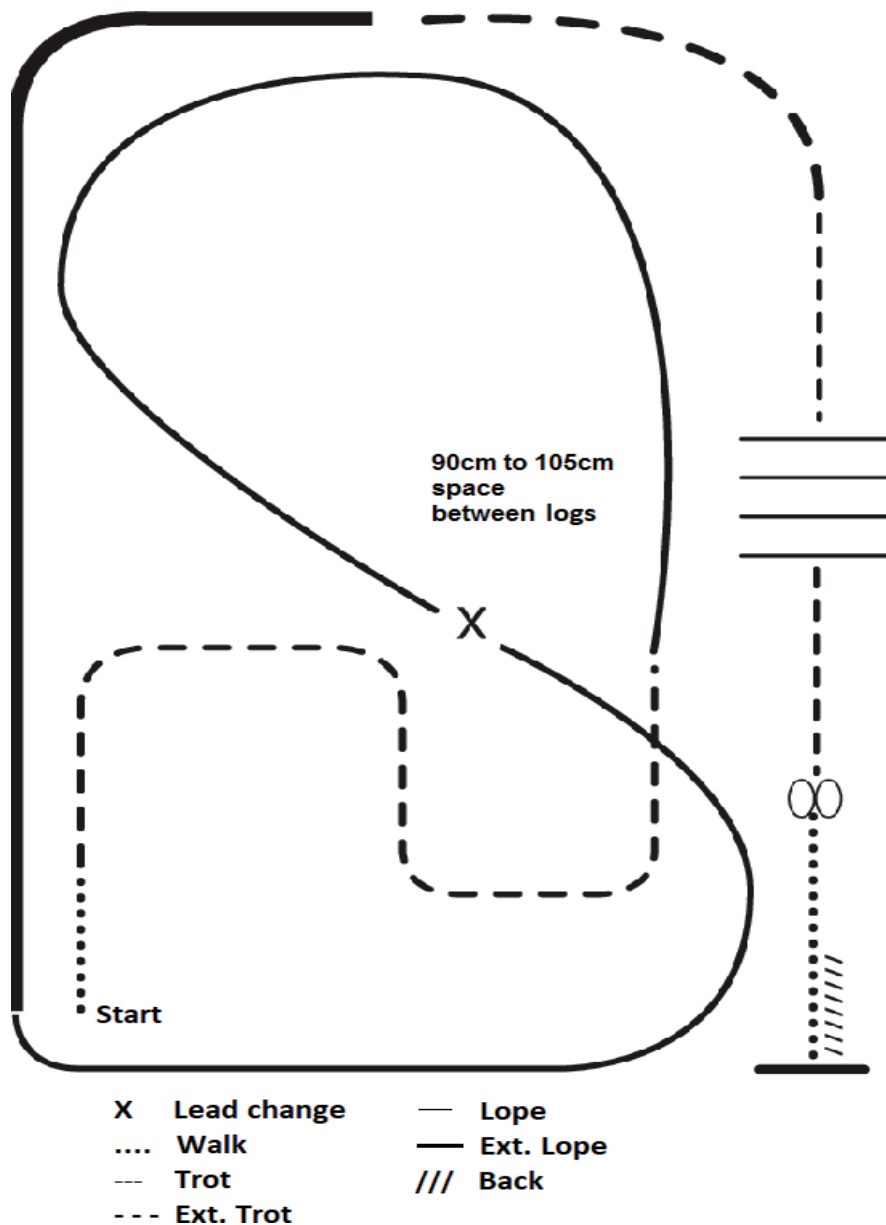

1. Walk
2. Trot serpentine
3. Lope left lead around the end of the arena and then diagonally across the arena
4. Change leads (simple or flying) and
5. Lope on right lead around end of arena
6. Extend lope on the straight away and around corner to the centre of the arena
7. Extend trot around corner of arena
8. Collect to a trot
9. Trot over logs
10. Stop, perform 360° turn each direction (either direction first)
11. Walk, stop and back

# RANCH RIDING PATTERN 4

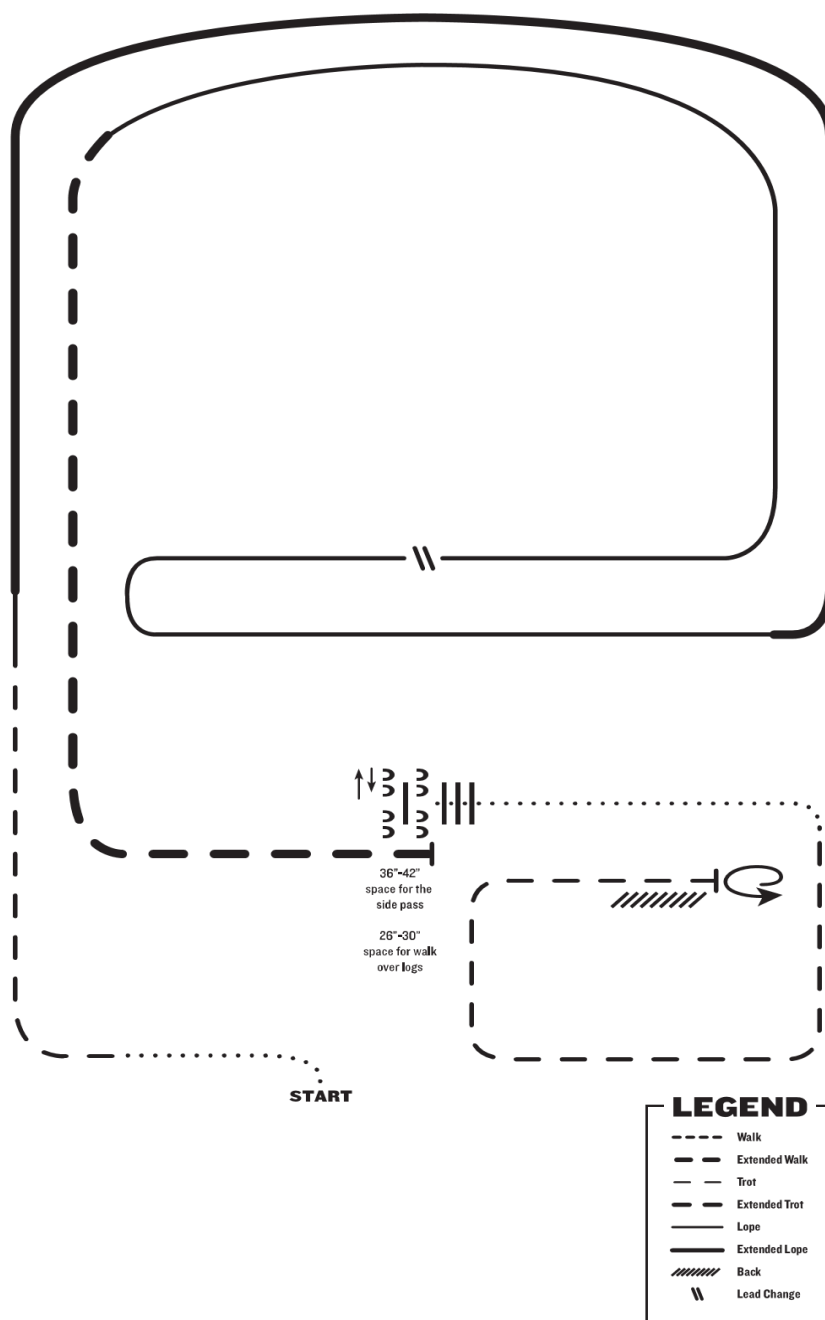

1. Walk
2. Trot
3. Extended lope right lead
4. Lope right lead
5. Change leads (simple or flying)
6. Lope left lead
7. Extended trot
8. Stop, side pass left, side pass right, 1/2 way
9. Walk over logs
10. Walk
11. Trot square
12. Stop, 360° turn left, and back

*Note: The drawn description of this pattern is only intended for the general depiction of the pattern. Exhibitors should utilize the arena space to best exhibit their horses.*

## RANCH RIDING PATTERN 5

OPTIONAL  
L

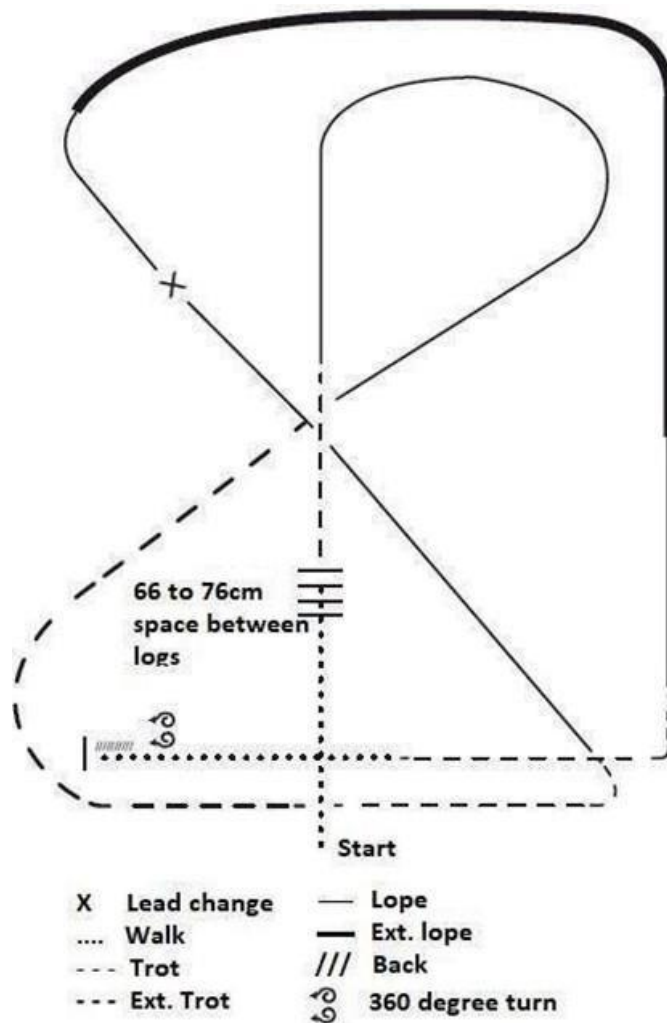

1. Walk
2. Walk over logs
3. Trot
4. Lope right lead
5. Extended trot
6. Trot
7. Lope left lead
8. Change leads (simple or flying)
9. Right lead, extended lope
10. Collect lope
11. Trot
12. Walk
13. Stop and back
14. 360° turn each direction (either direction first) (L-R or R-L)

## RANCH RIDING PATTERN 6

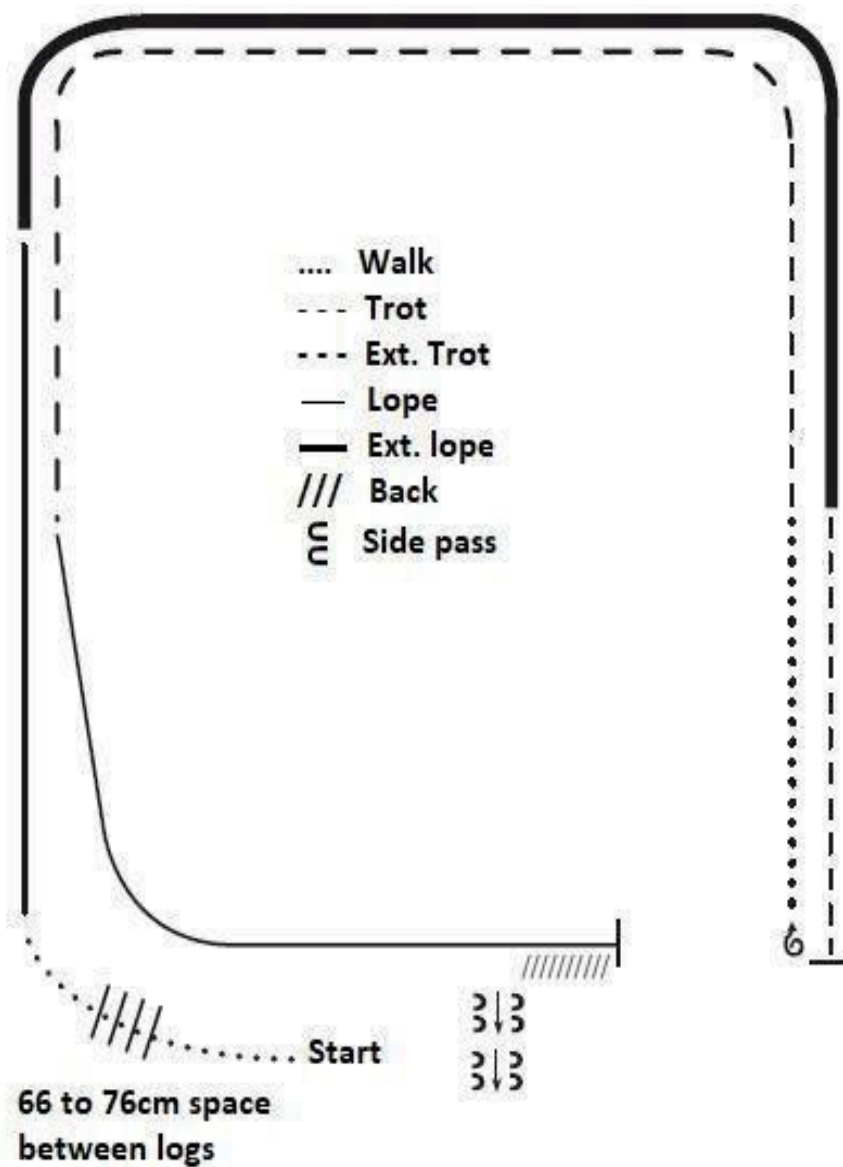

1. Walk
2. Walk over logs
3. Lope right lead
4. Extended lope right lead
5. Trot
6. Stop, 1½ turns right
7. Walk
8. Trot
9. Extended trot
10. Lope left lead
11. Stop and back
12. Side pass right



# RANCH RIDING PATTERN 8

1

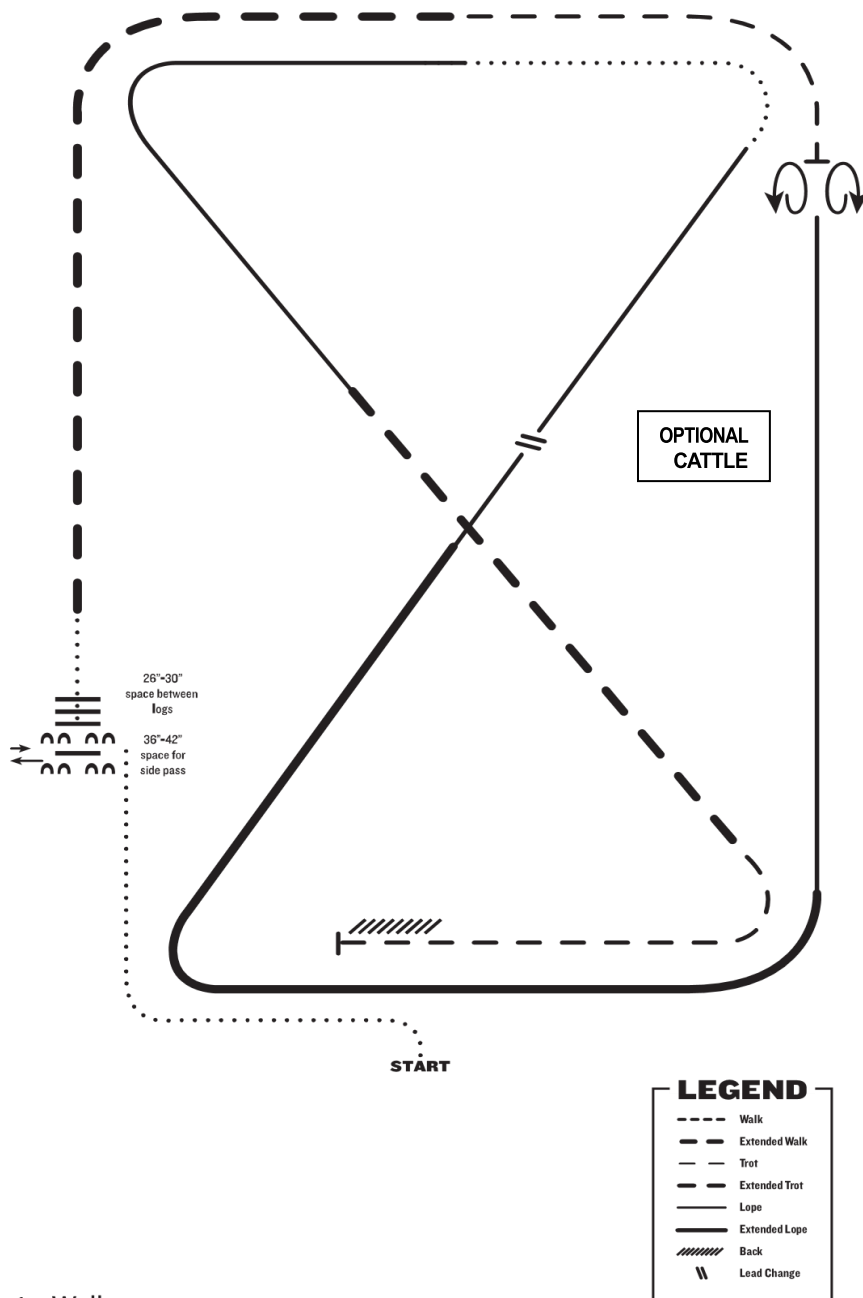

1. Walk
2. Side pass left across first log, side pass 1/2 way to right
3. Walk over logs
4. Extended trot
5. Trot
6. Stop, 360° turn each direction (either direction 1st) (L-R or R-L)
7. Lope right lead
8. Extended lope right lead
9. Collect lope, change leads (simple or flying), continue lope left lead
10. Walk
11. Lope left lead
12. Extended trot
13. Trot
14. Stop and back

*Note: The drawn description of this pattern is only intended for the general depiction of the pattern. Exhibitors should utilize the arena space to best exhibit their horses.*

## RANCH RIDING PATTERN 9

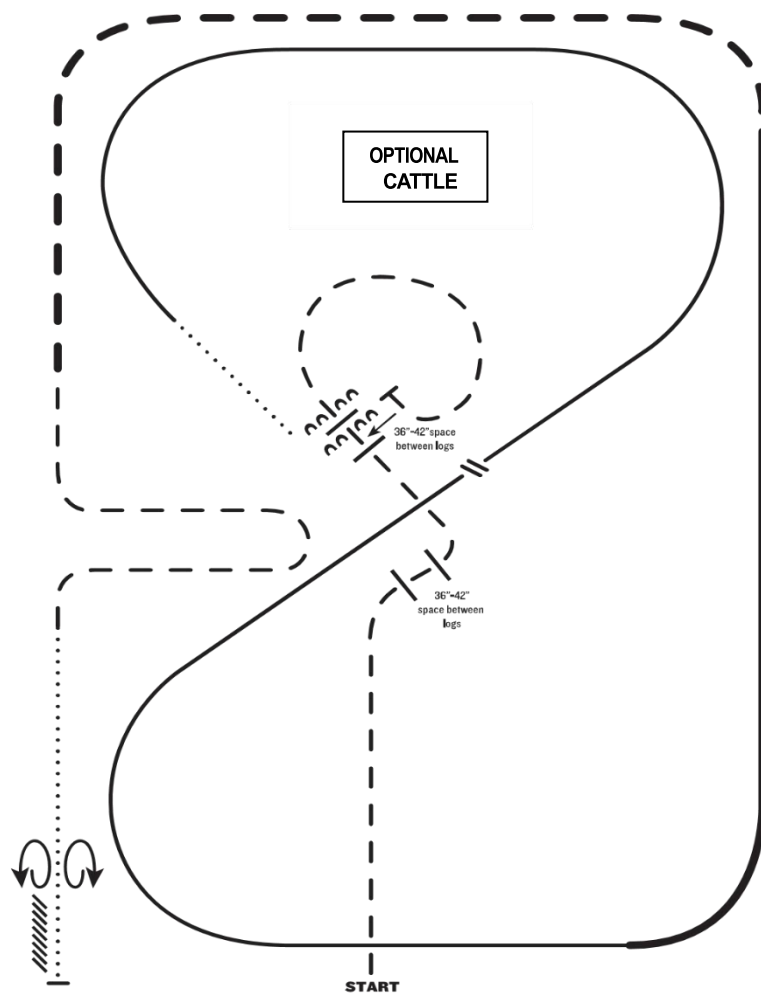

LEGEND	
----	Walk
- - - -	Extended Walk
- · - ·	Trot
- · - · - ·	Extended Trot
— · — ·	Lope
— · — · — ·	Extended Lope
////	Back
∩	Lead Change

1. Trot
2. Trot over two sets of logs
3. Trot circle, stop and side pass left over log
4. Walk
5. Lope right lead
6. Change leads (simple or flying)
7. Lope left lead
8. Extended lope left lead
9. Extended trot
10. Trot
11. Walk
12. Stop and back
13. 360° turn each direction (either direction 1st) (L-R or R-L)

*Note: The drawn description of this pattern is only intended for the general depiction of the pattern. Exhibitors should utilize the arena space to best exhibit their horses.*

# RANCH RIDING PATTERN 10

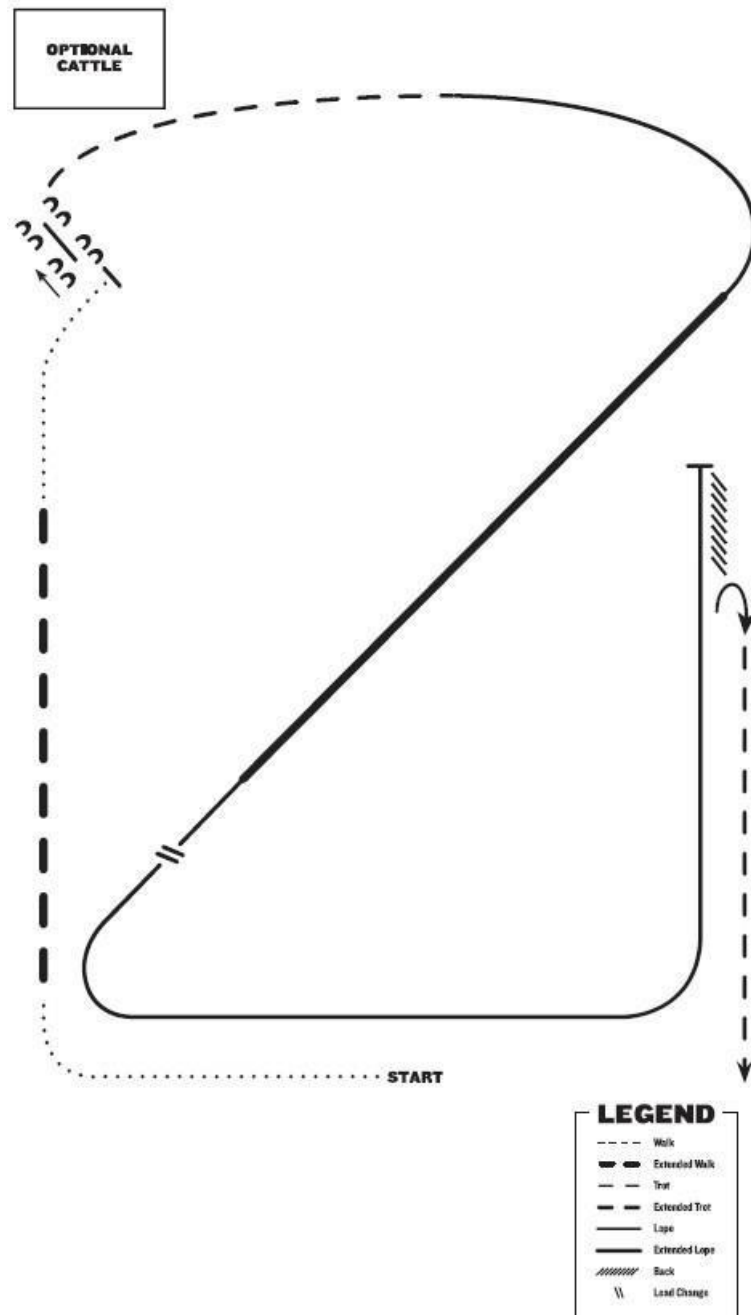

1. Walk
2. Extended trot
3. Walk
4. Stop, side pass left over log
5. Trot
6. Lope right lead
7. Extended lope right lead
8. Collect lope and change leads (simple or flying)
9. Lope left lead
10. Stop and back
11. 1/2 turn right
12. Trot

*Note: The drawn description of this pattern is only intended for the general depiction of the pattern. Exhibitors should utilize the arena space to best exhibit their horses.*

# RANCH RIDING PATTERN 11

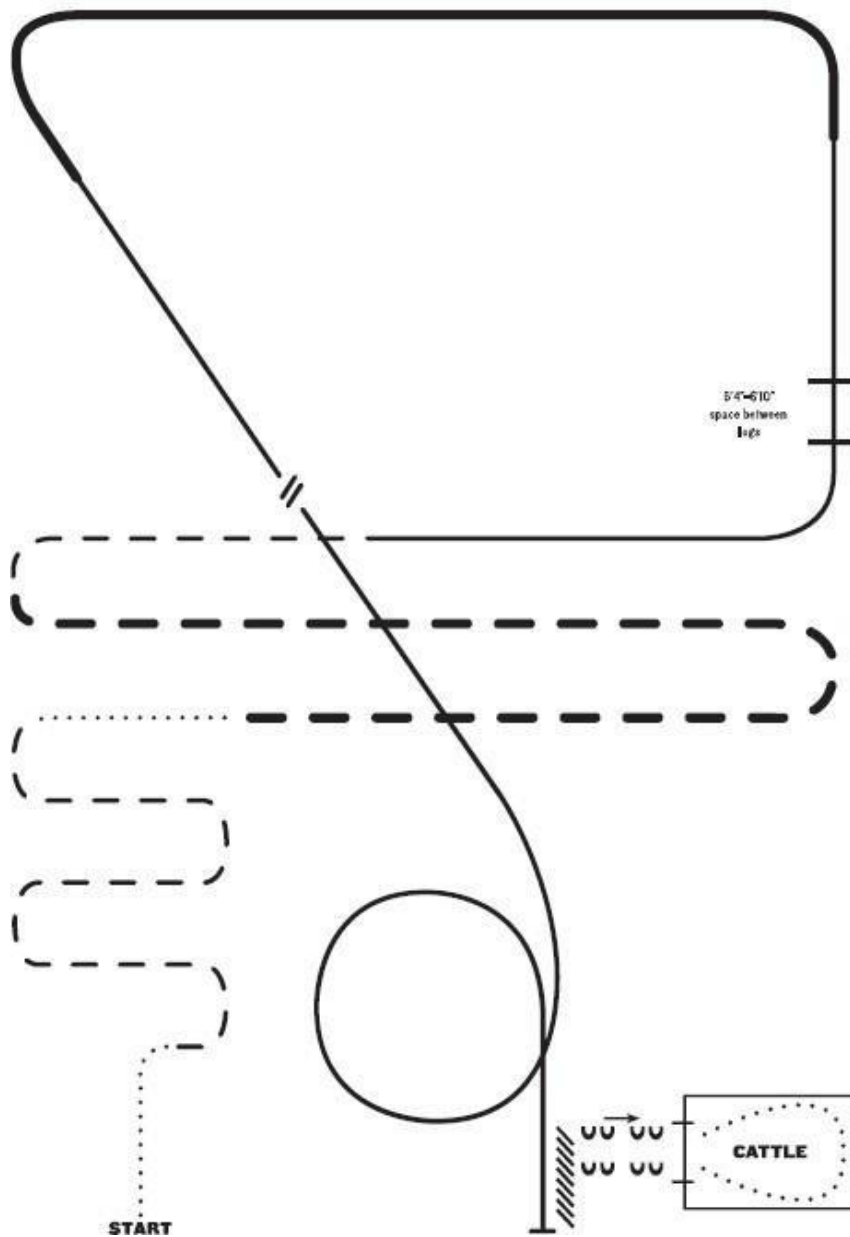

1. Walk
2. Trot serpentine
3. Walk
4. Extended trot
5. Trot
6. Lope left lead
7. Lope over logs
8. Extended lope left lead
9. Collect lope, change leads (simple or flying)
10. Lope right lead
11. Lope circle
12. Stop and back
13. Side pass to gate, left hand push into pen
14. Walk through cattle, right hand push out

*Note: The drawn description of this pattern is only intended for the general depiction of the pattern. Exhibitors should utilize the arena space to best exhibit their horses.*

# RANCH RIDING PATTERN 12

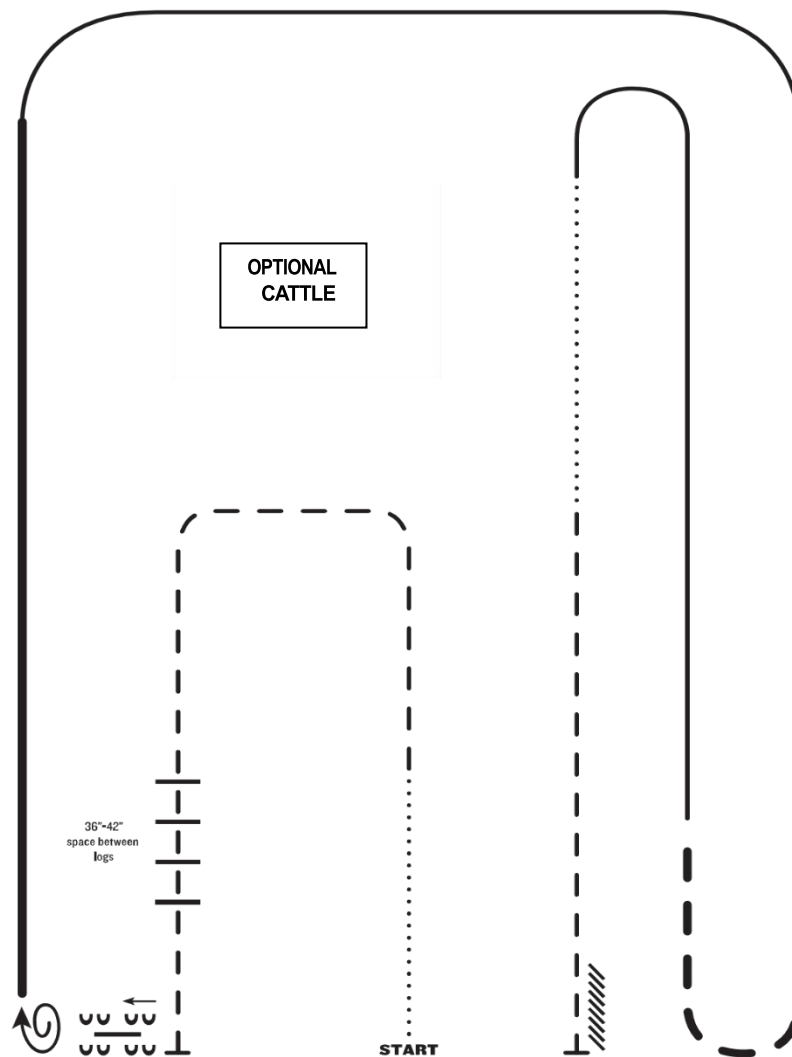

1. Walk
2. Trot
3. Trot over logs, stop
4. Side pass right over log
5. 1 1/2 turn right
6. Extended lope right lead
7. Lope right lead
8. Extended trot
9. Lope left lead
10. Walk
11. Trot
12. Stop and back

LEGEND	
----	Walk
- - - -	Extended Walk
- . - .	Trot
- - - -	Extended Trot
— — — —	Lope
— — — —	Extended Lope
////	Back
∩	Lead Change

*Note: The drawn description of this pattern is only intended for the general depiction of the pattern. Exhibitors should utilize the arena space to best exhibit their horses.*

# RANCH RIDING PATTERN 13

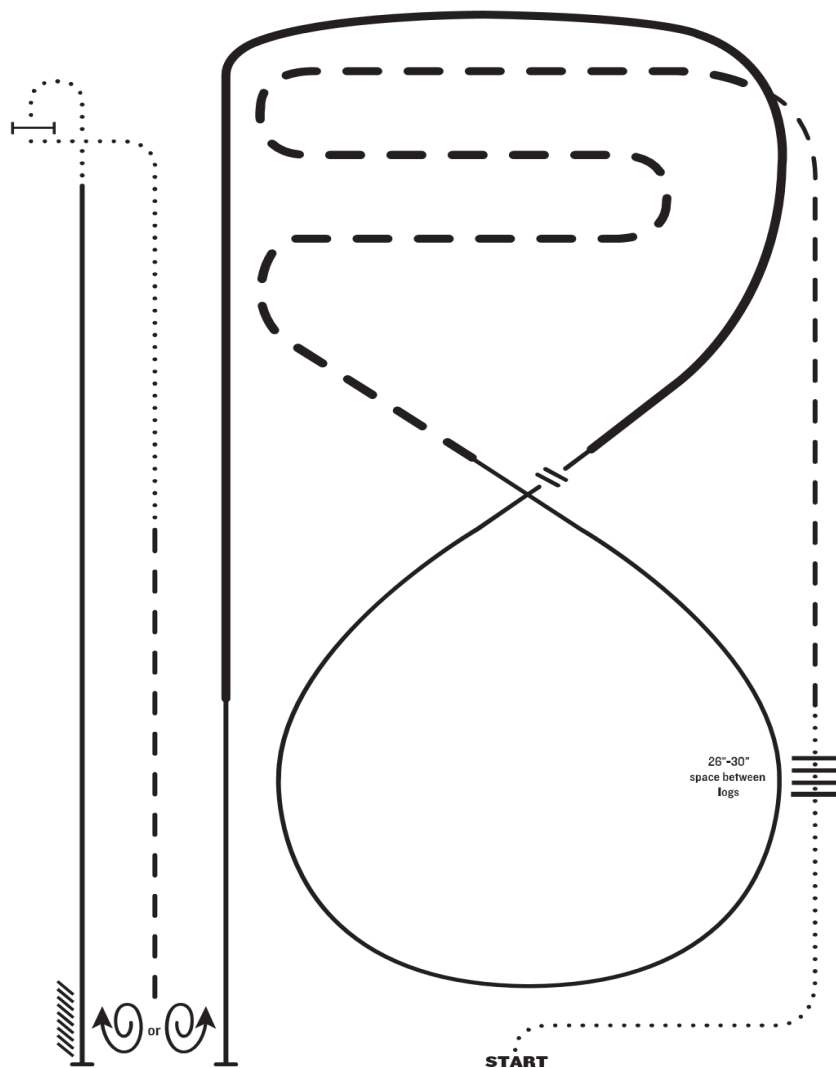

1. Walk
2. Walk over logs
3. Trot
4. Extended trot serpentine
5. Lope right lead
6. Change leads (simple or flying)
7. Extended lope left lead, collect lope
8. Stop, 1 1/2 turn either direction
9. Trot
10. Walk to gate
11. Right hand push gate
12. Walk, lope left lead
13. Stop and back

LEGEND	
----	Walk
- - - -	Extended Walk
- · - ·	Trot
- - - -	Extended Trot
— · — ·	Lope
— · — ·	Extended Lope
////	Back
W	Lead Change

*Note: The drawn description of this pattern is only intended for the general depiction of the pattern. Exhibitors should utilize the arena space to best exhibit their horses.*

# RANCH RIDING PATTERN 14

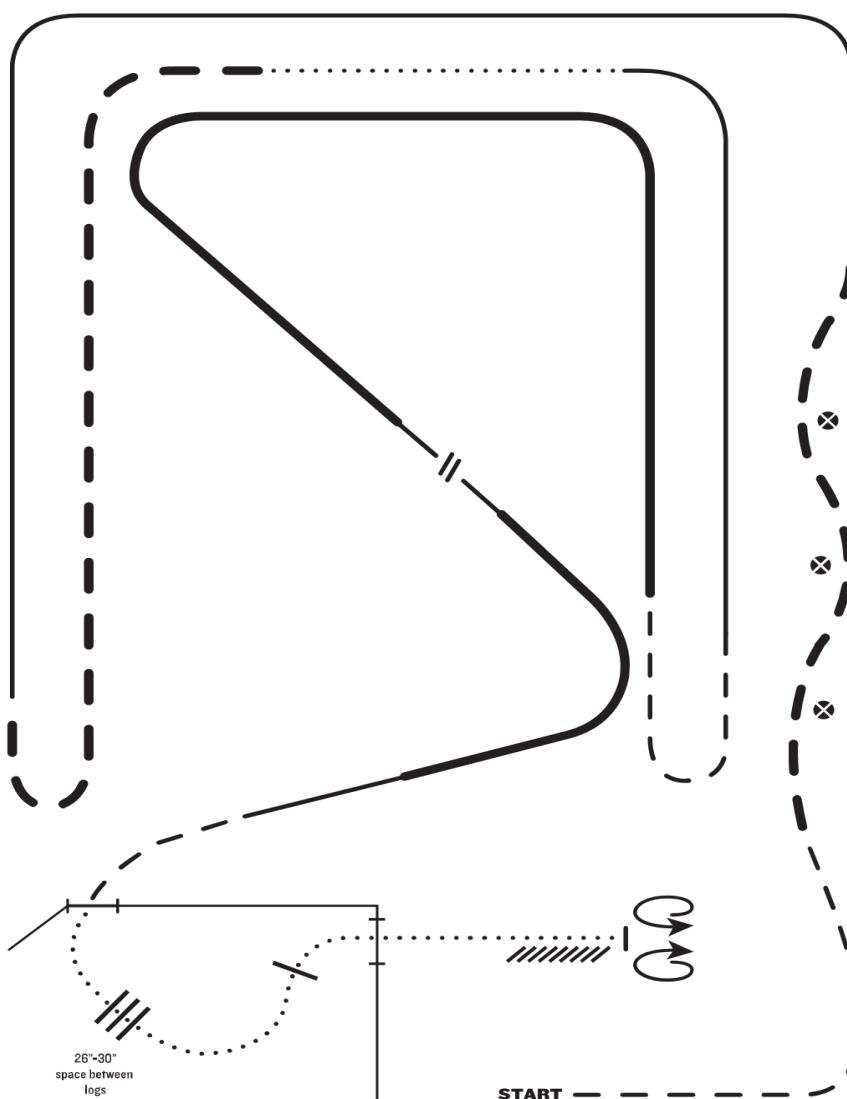

1. Trot
2. Extended trot
3. Lope left lead
4. Extended trot
5. Walk
6. Lope right lead
7. Trot
8. Extended lope left lead
9. Collect lope, change leads (simple or flying), extended lope right lead, collect lope
10. Trot
11. Left hand push gate into pen
12. Walk over logs
13. Right hand push gate out of pen
14. Walk
15. Stop, 360° turn each direction (either direction 1st) (L-R or R-L)
16. Back

LEGEND	
----	Walk
- - - -	Extended Walk
— — — —	Trot
- - - -	Extended Trot
— — — —	Lope
— — — —	Extended Lope
////	Back
∩	Lead Change

*Note: The drawn description of this pattern is only intended for the general depiction of the pattern. Exhibitors should utilize the arena space to best exhibit their horses.*



## RANCH REINING PATTERN 1

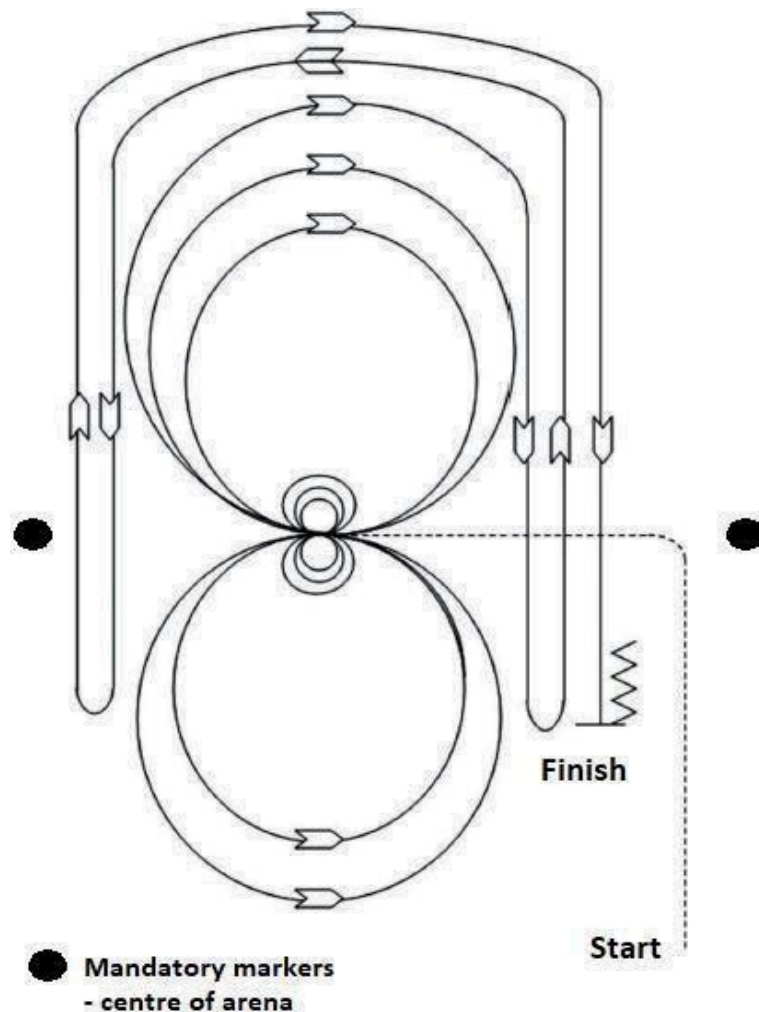

Ride pattern as follows: Trot to centre of arena and stop.

1. Complete three (3) spins in one direction. Hesitate
2. Complete three (3) spins in the opposite direction. Hesitate
3. Beginning on right lead, complete two (2) large fast circles to the right. Change leads at centre of arena (flying)
4. Complete two (2) large fast circles to the left. Change leads (flying) at centre of arena
5. Begin a large circle to the right but do not close this circle. Run down right side of arena past centre marker and do a left rollback at least 6 m from the wall, no hesitation
6. Continue back around the previous circle but do not close this circle. Run down left side of arena past centre marker and do a right rollback at least 6 m from wall, no hesitation
7. Continue back around previous circle, but do not close this circle. Run down right side of arena past centre marker and do a sliding stop at least 6 m from the wall. Back up at least 3 m. Hesitate to show completion of pattern

## RANCH REINING PATTERN 2

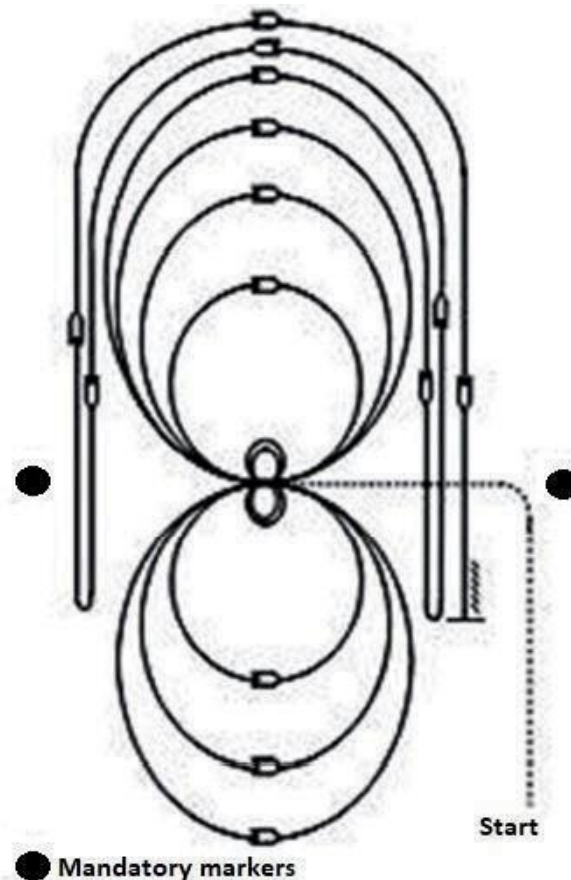

Ride pattern as follows: Trot to centre of arena and stop or walk before departure.

1. Beginning on right lead complete two (2) circles to the right, the first one large and fast, the second small and slow. Stop at centre
2. Complete four (4) spins to the right. Hesitate.
3. Beginning on left lead complete two (2) circles to the left, the first large and fast, the second small and slow. Stop at centre
4. Complete four (4) spins to the left. Hesitate
5. Beginning on right lead complete a large fast circle to the right and change leads (flying) at centre of arena. Complete a large fast circle to the left and change leads (flying) at centre of arena
6. Begin a large fast circle to the right, but do not close this circle. Run down right side of arena past centre marker and do a left rollback at least 6 m from wall
7. Continue back around previous circle but do not close this circle. Run down left side of arena past centre marker and do a right rollback at least 6 m from wall
8. Continue back around previous circle but do not close this circle. Run down right side of arena past centre marker and do a sliding stop at least 6 m from wall. Back up at least 3m. Hesitate to show completion of pattern.

## RANCH REINING PATTERN 3

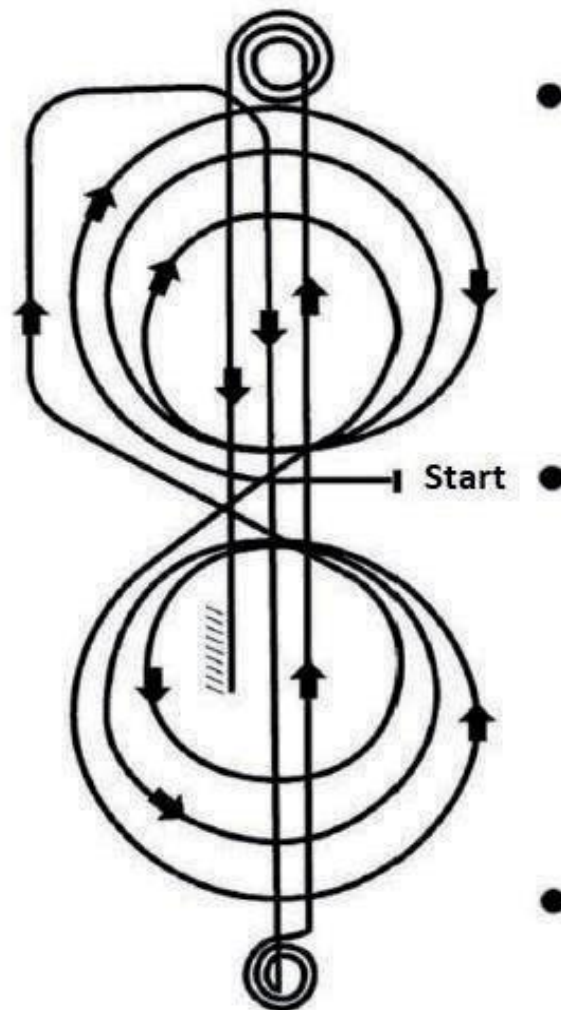

● **Mandatory Markers - centre and at least 15 metres from each end of arena**

Ride pattern as follows: Trot to centre of arena and stop or walk before departure. Start pattern facing toward the Judge.

1. Beginning on right lead, complete three (3) circles to the right –the first two large and fast. the third small and slow. Change leads (flying) at centre of arena
2. Complete three (3) circles to the left: the first two large and fast, the third small and slow. Change leads (flying) at centre of arena
3. Begin a large circle to the right, but do not close this circle. Run down centre of arena, past end marker, and do a sliding stop
4. Complete 3½ spins to the right
5. Run up centre of arena to the opposite end, past end marker, do a sliding stop
6. Complete 3½ spins to the left
7. Run back to middle of arena, past centre marker and do a sliding stop. Back up at least 3 m. Hesitate to show completion of pattern.

## RANCH REINING PATTERN 4

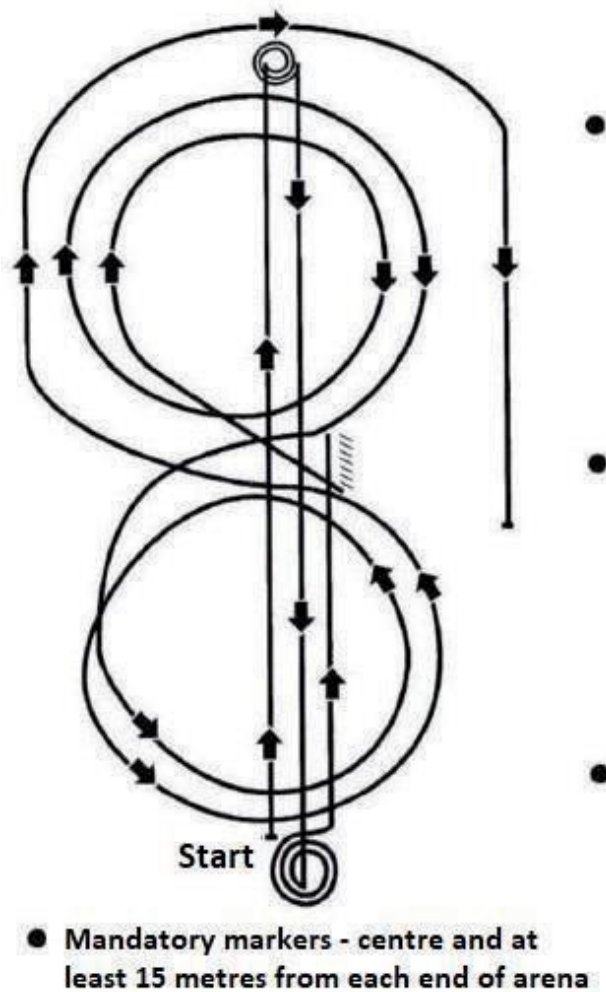

Ride pattern as follows:

1. Run up centre of arena past end marker and do a sliding stop
2. Complete 3½ spins to the left
3. Run down to opposite end of arena, past end marker and do a sliding stop
4. Complete 3½ spins to the right
5. Run past centre marker and do a sliding stop. Back at least 3 m. Complete ¼ turn to the left. Hesitate
6. Beginning on right lead, complete two (2) circles to the right – the first small and slow, the second large and fast. Change leads (flying) at centre of arena
7. Complete two (2) circles to the left – the first small and slow, the second large and fast. Change leads (flying) at centre of arena
8. Begin a large circle to the right, but do not close circle. Run down right side of arena past centre marker and do a sliding stop at least 6 m from the fence. Hesitate to show completion of pattern.

## RANCH REINING PATTERN 5

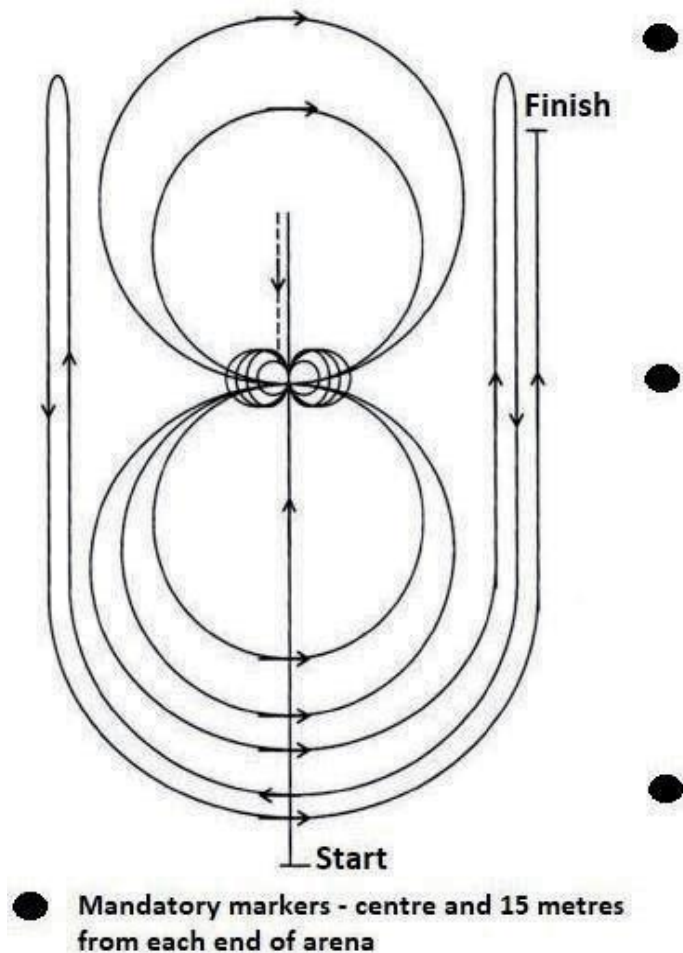

Ride pattern as follows:

1. Run past centre marker and do a sliding stop. Back to centre of arena or at least 3 m. Hesitate
2. Complete four (4) right spins. Hesitate
3. Complete 4¼ left spins. Hesitate. Horse to be facing left wall
4. Beginning on left lead, complete two (2) circles to the left – the first small and slow, the second large and fast Change leads (flying) at centre of arena
5. Complete two (2) circles to the right – the first small and slow, the second large and fast. Change leads (flying) at centre of arena
6. Begin a large circle to the left, but do not close circle. Run up left side of arena past centre marker and do a right rollback at least 6 m from wall
7. Continue back around the previous circle, but do not close circle. Run up left side of arena past centre marker and do a left rollback at least 6 m from wall
8. Continue back around previous circle but do not close circle. Run up right side of arena past centre marker, and do a sliding stop at least 6 m from wall. Hesitate to show completion of pattern

## RANCH REINING PATTERN 6

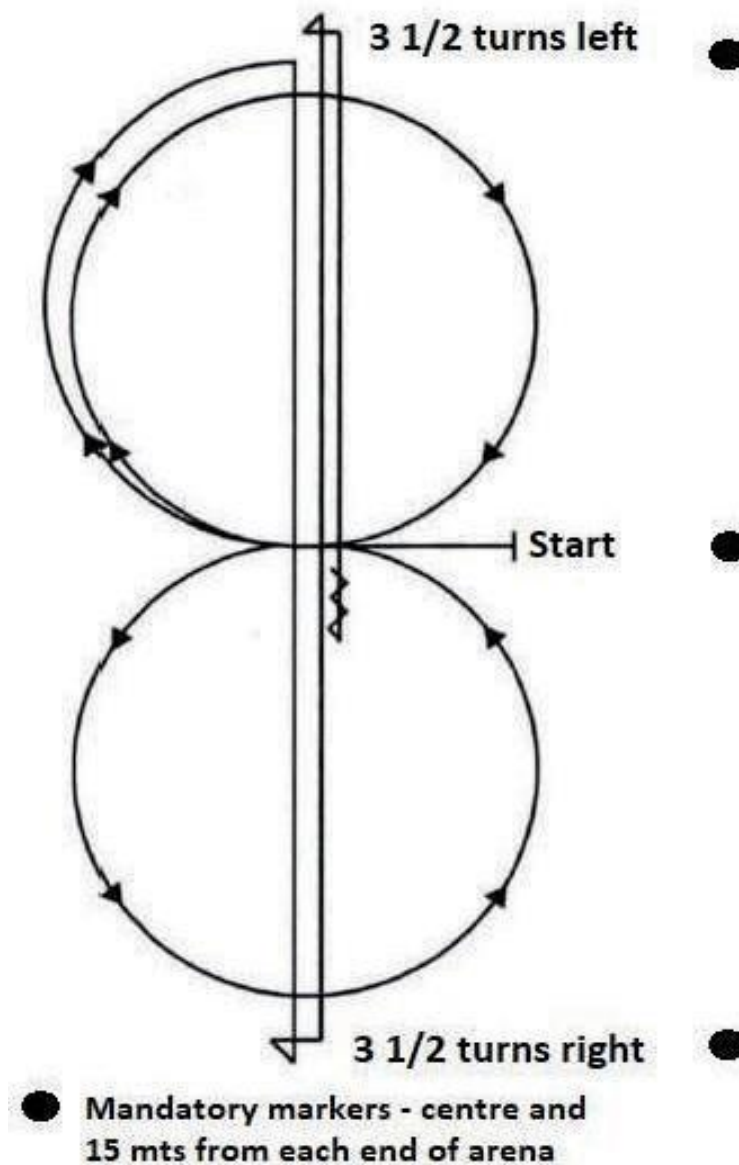

Ride pattern as follows: Trot to centre of arena and stop or walk before departure. Start pattern facing toward Judge.

1. Beginning on right lead, lope one (1) circle to the right. Change leads (flying) at centre of arena
2. Complete one (1) circle to the left. Change leads (flying) at centre of arena.
3. Begin a circle to the right but do not close this circle. Run down centre of arena past end marker and do a sliding stop.
4. Complete 3½ spins to the right.
5. Run up to the other end of arena, past end marker and do a sliding stop.
6. Complete 3½ spins to the left.
7. Run past centre marker and do a sliding stop. Back at least 3 m. Hesitate to show completion of pattern.

## REINING PATTERN 7

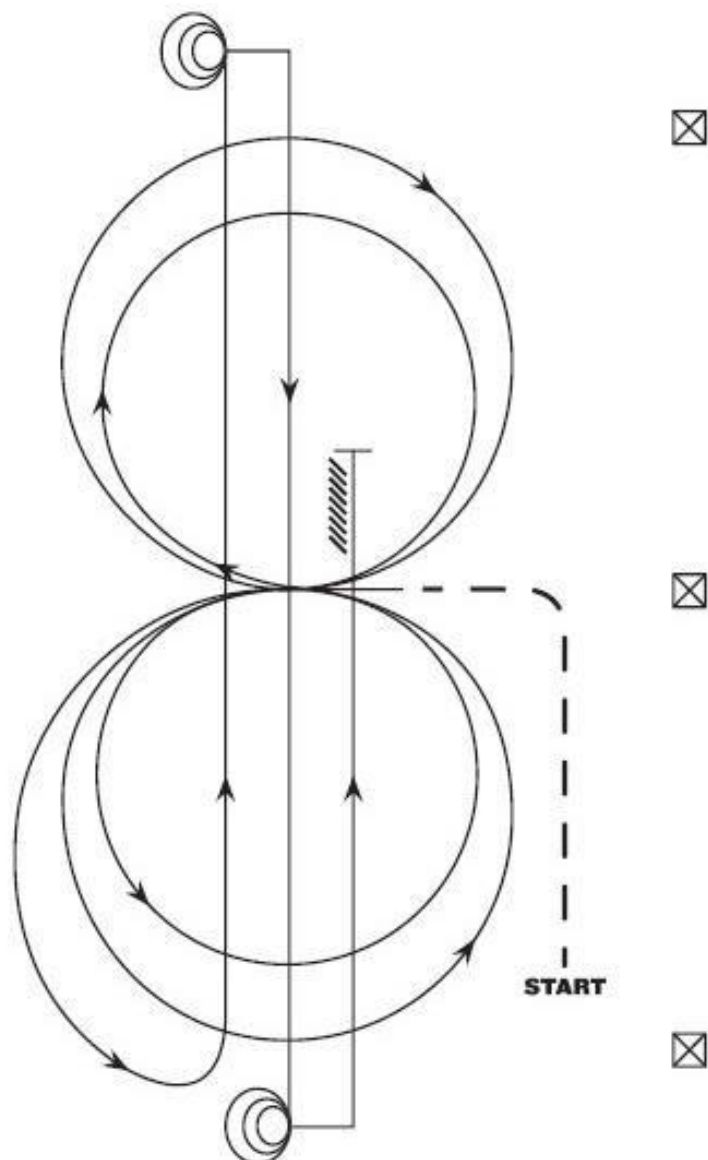

**Mandatory Marker along Fence or Wall:** The judge shall indicate with markers on arena wall or fence the center of pattern. Judge shall also place markers on fence or wall at least 50' from each end of the arena.

Ride pattern as follows: Trot to center of arena and stop or walk before departure. Start pattern facing toward judge.

1. Beginning on left lead, complete two circles to the left - the first one large and fast, the second one small and slow. Change leads at center of arena.
2. Complete two circles to the right - the first one large and fast, the second one small and slow. Change leads at center of arena.
3. Begin a circle to the left, but do not close this circle. Continuing around the end of arena, run up the center, past end marker, and do a sliding stop.
4. Complete 3 1/2 spins to the left.
5. Run down to other end of arena, past the end marker, and do a sliding stop.
6. Complete 3 1/2 spins to the right.
7. Run past the center marker and do a sliding stop. Back at least 10 feet. Hesitate to show completion pattern.